

MILK JUG TOSSES™



ICE™



Innovative Concepts in Entertainment, Inc.
10123 Main Street Clarence New York USA 14031
PH:(716) 759-0370 FX: (716) 759-0390
E-mail:play@icegame.com www.icegame.com

Table of Contents

| | |
|--|-------|
| Safety, Warnings, and Power Requirements | 4 |
| Game Introduction and setup advisory | 5 |
| Setup | |
| Assembly | |
| Cages already attached, start here. | 6-9 |
| Cabinet is in two pieces, start here. | 10-16 |
| Optional Marquee install instructions. | 17-22 |
| Decal Install Locations | 23 |
| Game Options | 24 |
| Accounting | 26 |
| Error Codes | 27 |
| Score Sensor Layout | 28 |
| Playfield Service | 29 |
| Illegal Ball Sizes | 30 |
| Service | |
| Main board access | 31 |
| Power supply access | |
| PLL bulb replacement | |
| Ball count sensor | 32 |
| Score sensors | 33 |
| Power supply troubleshooting | 36 |
| Playfield display access and replacement | 37 |
| Conveyor | 38 |
| Marquee bulb replacements | 39 |
| Schematics | 40 |
| Spares | 45 |
| Graphic Location and Part Numbers | 46 |
| Warranty | 47 |

SAFETY AND WARNINGS BEFORE YOU BEGIN

WARNING: WHEN INSTALLING THIS GAME, A GROUNDED A.C. RECEPTACLE MUST BE USED. FAILURE TO DO SO COULD RESULT IN INJURY TO YOURSELF OR OTHERS. FAILURE TO USE A GROUNDED RECEPTACLE COULD ALSO CAUSE IMPROPER GAME OPERATION, OR DAMAGE TO THE ELECTRONICS.

NOTE: THIS GAME IS INTENDED FOR INDOOR USE ONLY.

DO NOT DEFEAT OR REMOVE THE GROUNDING PRONG ON THE POWER CORD FOR THE SAME REASON AS GIVEN ABOVE. USING AN IMPROPERLY GROUNDED GAME COULD VOID YOUR WARRANTY.

HAVE A QUALIFIED ELECTRICIAN CHECK YOUR A.C. RECEPTACLE TO BE SURE THE GROUND IS FUNCTIONING PROPERLY.

THIS GAME IS DESIGNED TO DISSIPATE STATIC ELECTRICITY THROUGH THE GROUNDING PLANE OF THE GAME. IF THE A.C. GROUND DOES NOT WORK, THE GAME COULD DISCHARGE STATIC ELECTRICITY THROUGH THE GAME CIRCUITRY, WHICH COULD CAUSE DAMAGE.

THE POWER SUPPLY IS NOT VOLTAGE ADJUSTABLE. TO OPERATE THE GAME AT VOLTAGES OTHER THAN THOSE IT WAS DESIGNED FOR. PLEASE CONTACT OUR SERVICE DEPARTMENT FOR VOLTAGE CONVERSION INFORMATION.

WARNING

DO NOT remove any of the components on the main board (e.g. compact flash and eproms) while the game is powered on. This may cause permanent damage to the parts and the main board. Removing any main board component part while powered on will void the warranty.

ALWAYS REMOVE POWER TO THE GAME, BEFORE ATTEMPTING ANY SERVICE, UNLESS NEEDED FOR SPECIFIC TESTING. FAILURE TO OBSERVE THIS PRECAUTION COULD RESULT IN SERIOUS INJURY TO YOURSELF OR OTHERS.

THIS GAME IS NOT SUITABLE FOR INSTALLATION IN AN AREA WHERE A WATER JET COULD BE USED.

This appliance is not intended for use by persons (including children) with reduced physical, sensory or mental capabilities, or lack of experience and knowledge, unless they have been given supervision or instruction concerning use of the appliance by a person responsible for their safety. Children should be supervised to ensure that they do not play with the appliance

AC Power Information

The games main fuse is accessed through the back of the game at the power mod. Above the power cord is a small panel that contains the main fuse. The value of the fuse for 110 volt users is 6 AMPS at 250Volt type slow blow. The value of the fuse for 220 users is 3 AMPS at 250Volt type slow blow.



Game Introduction:

The all time carnival hit is now a redemption game. Players skillfully toss the balls into the milk jug or surrounding holes to win tickets. The interactive “Carny” voice heckles and entertains players, while they shoot for the Super Bonus by getting all the balls in the jug.



STOP– Important setup info:

Your game can be configured in different ways. We have included decals that you need to apply to match your desired settings. Please read all of the setup sections and programming recommendations before you begin to assemble your game. The Graphic decals can be applied at any time and can be changed later if desired.

SETUP - Shipped with cages attached assembly instructions.

The game can be shipped in two ways. Follow these Instructions if your game was shipped with both the front half, back half, and cages completely assembled together and only the canopy is not attached. If your game is split in half, see the section entitled “**Separated Cabinet Assembly**”.

Step 1:

Remove ties that hold the upper supports to the shipping 2x4 and lift the upper supports up.

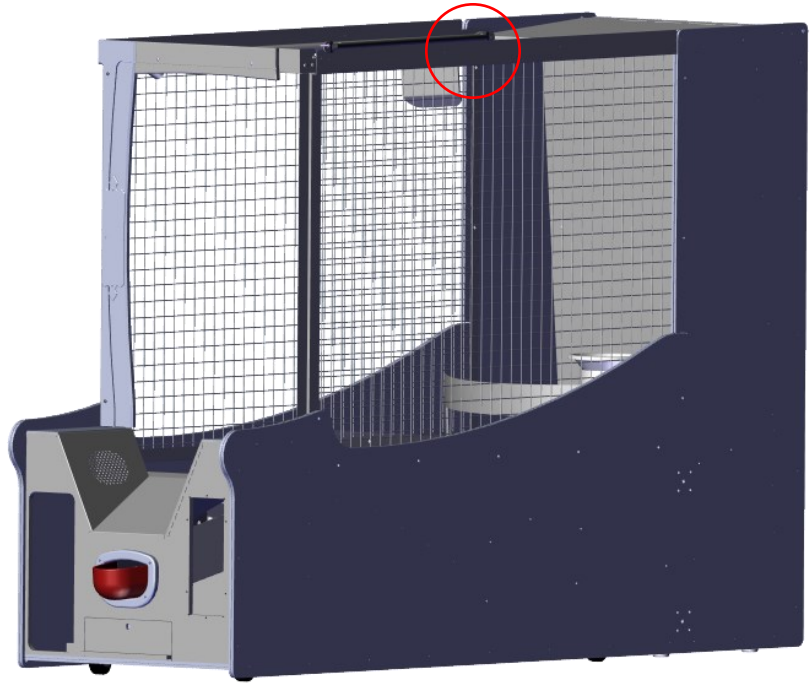

Step 2:

Raise the bars to their upright position.

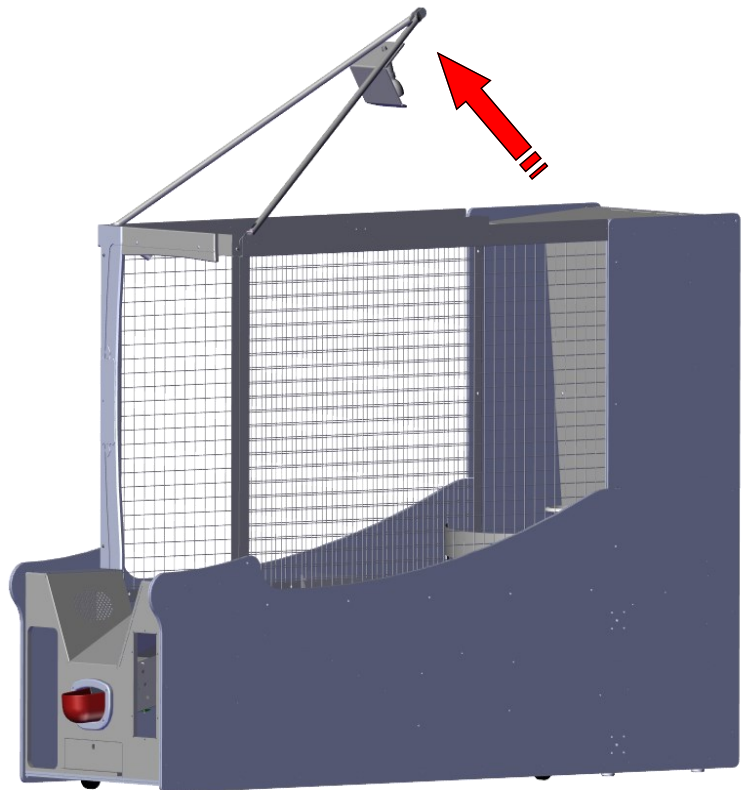

Step 3:

Attach the upper back supports to the front back supports using the supplied hardware as shown. At this time attach the earth ground wire to the grounding lug at the light. Connect the AC harness for the light fixture. Tighten all hardware. It is recommended to use a long extension when attach the Allen bolts.

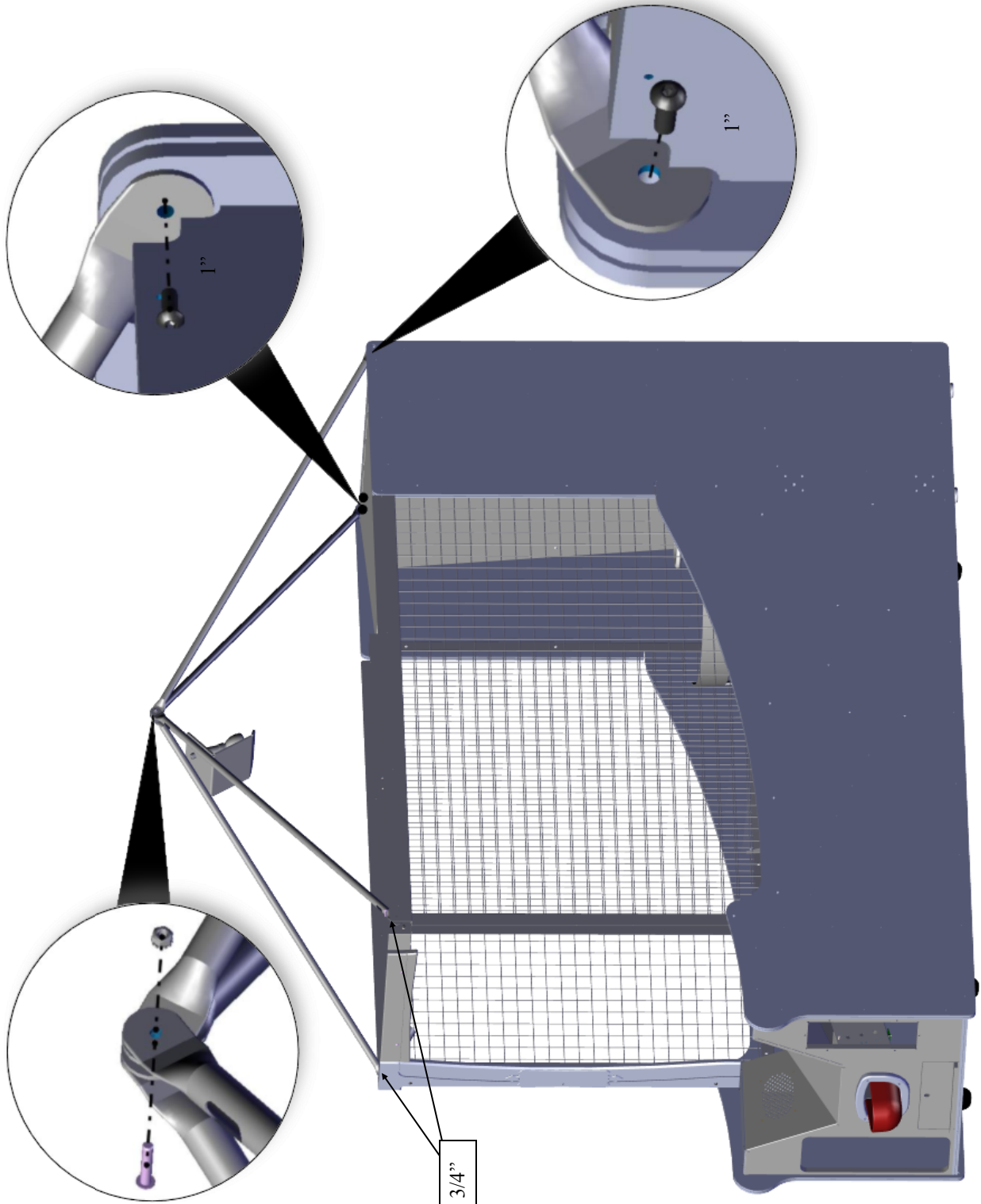

Step 4:

Before proceeding it is recommended to apply the decals to this before installing. See page 18 for recommended settings. Attach the upper bonus Jug sign using the self tapping Robinson screws following the predrilled holes shown below.

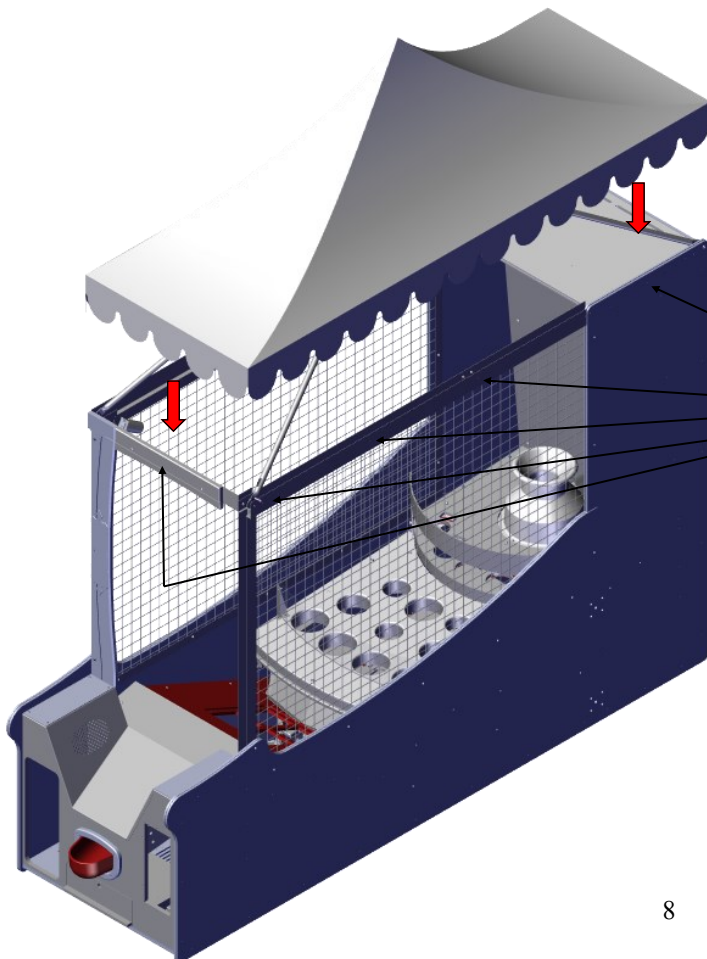
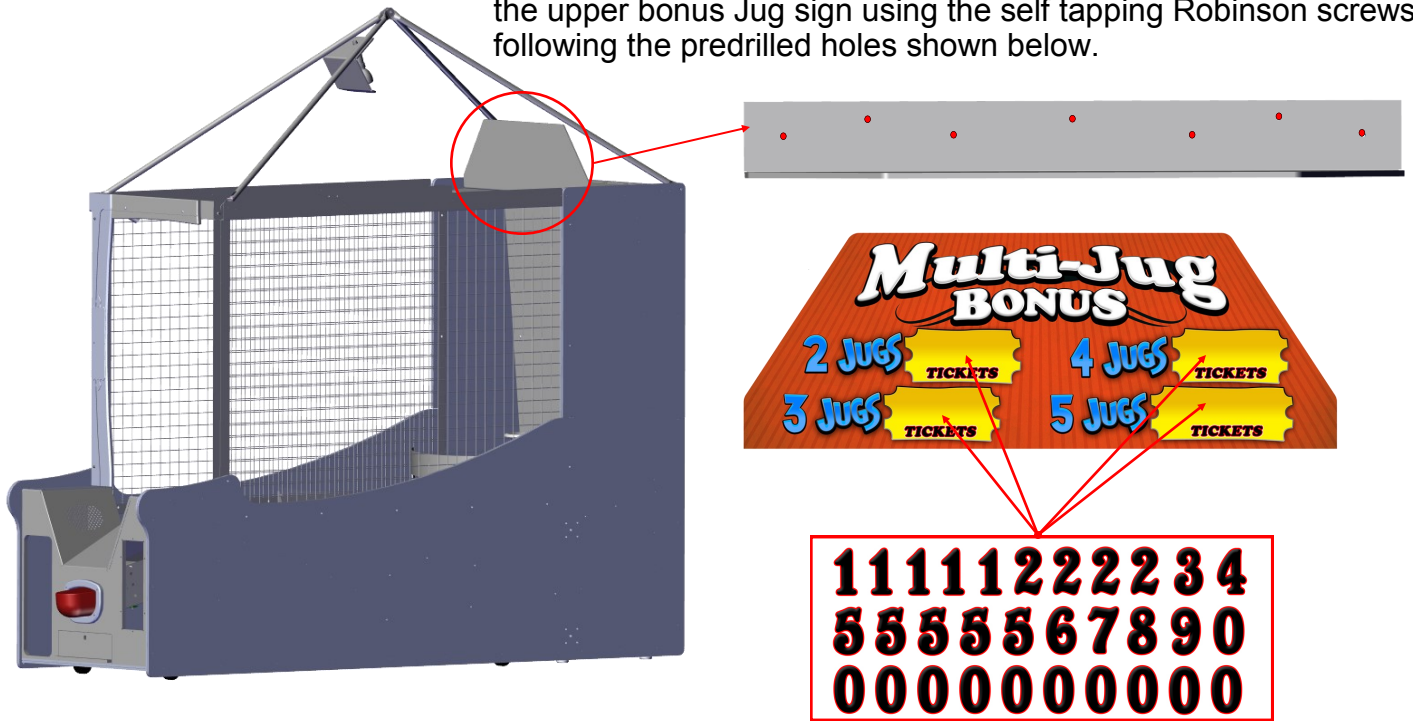

Step 5:

Attach the upper marquee using the self tapping Robinson screws following the arrows shown. Only one side is shown for clarity.

Step 6:

Finally raise the back end of the game by twisting the back leg levers counter-clockwise. It is important not to have the game totally leveled but instead, have the back slightly raised enough so that the balls can return to the conveyor easier. If you find that your balls are getting hung up when returning to the conveyor, you do not have the back raised enough.

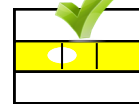
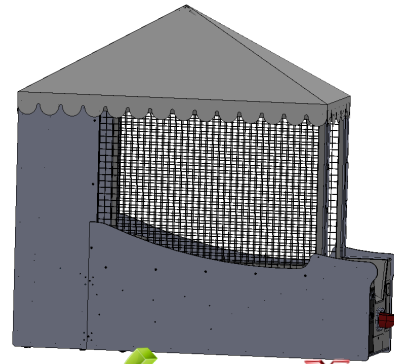
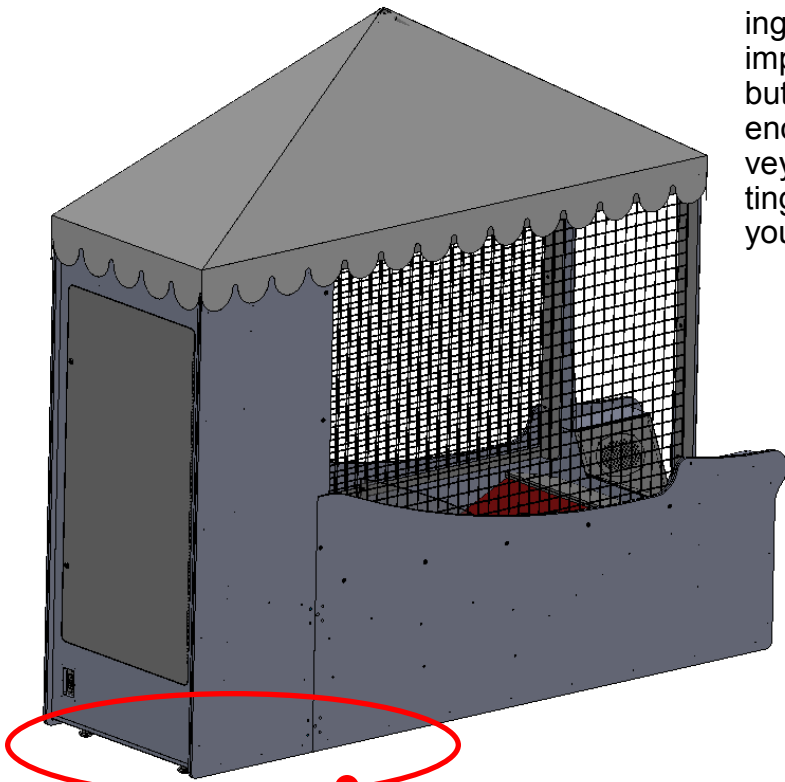

NOT LEVEL

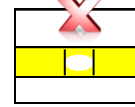

LEVEL

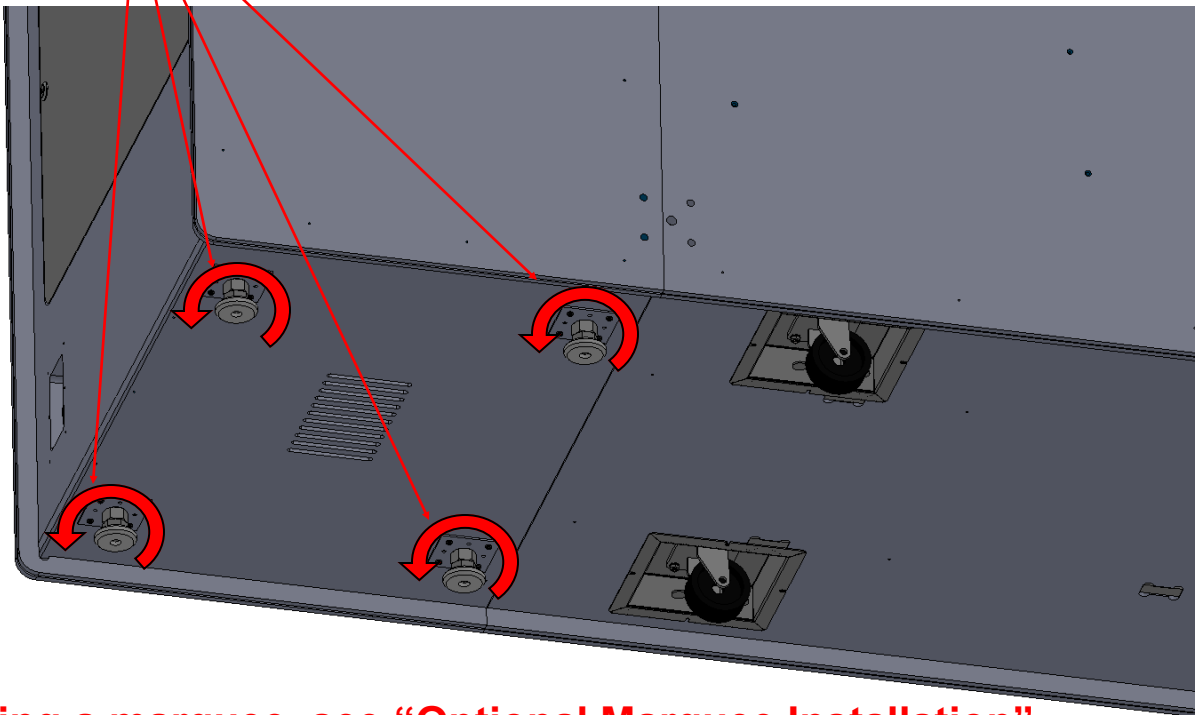

**If installing a marquee, see “Optional Marquee Installation”.
If not installing a marquee, proceed to “Decal Install locations”.**

SETUP - Separated cabinet assembly instructions

If your game has been shipped with the back and front separated, follow these instructions first.

Step 1:

Position the two halves as shown and on the left side attach the signal wire harnesses and on the right side attach the AC harness. Now slide the two halves together.

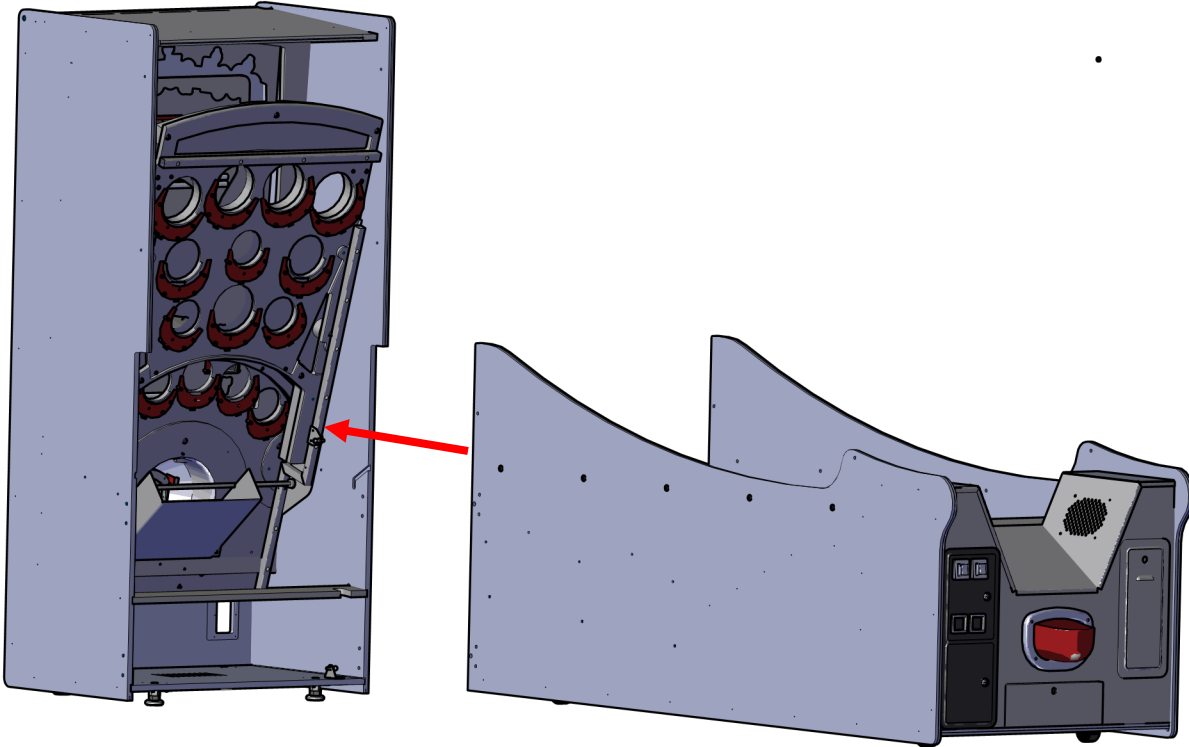

Step 2:

Using the provided latch tool, latch the front half to the back half by inserting the wrench into the hex holes and turning clockwise.

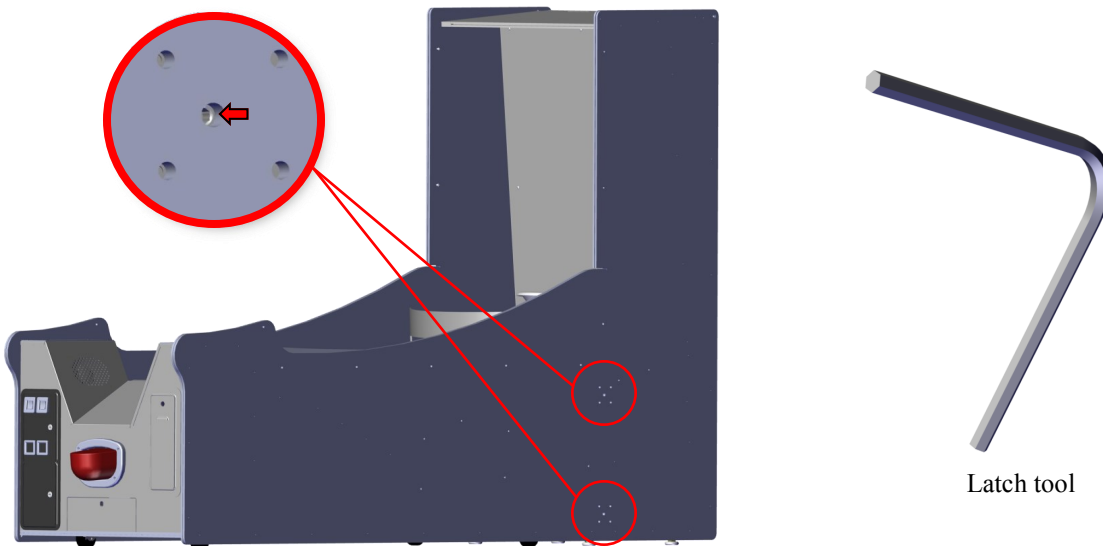

Step 3

Slide the cages down and inside the bottom cabinet. Attach the cages to the cabinet using hat nuts on the outside and 1/4-20 bolts on the inside to the two locations shown below. **DO NOT TIGHTEN AT THIS TIME.**

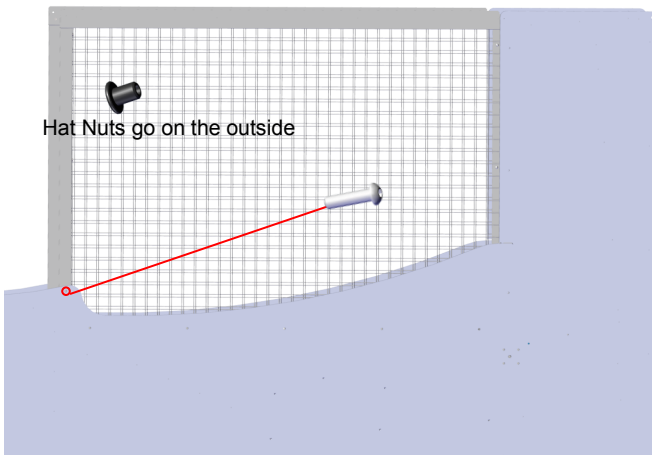
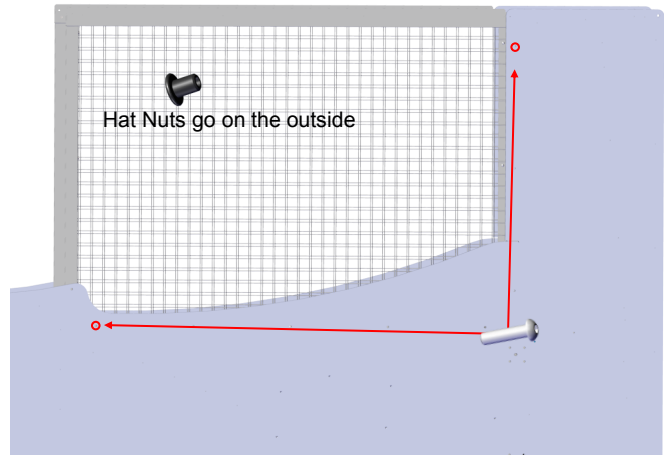
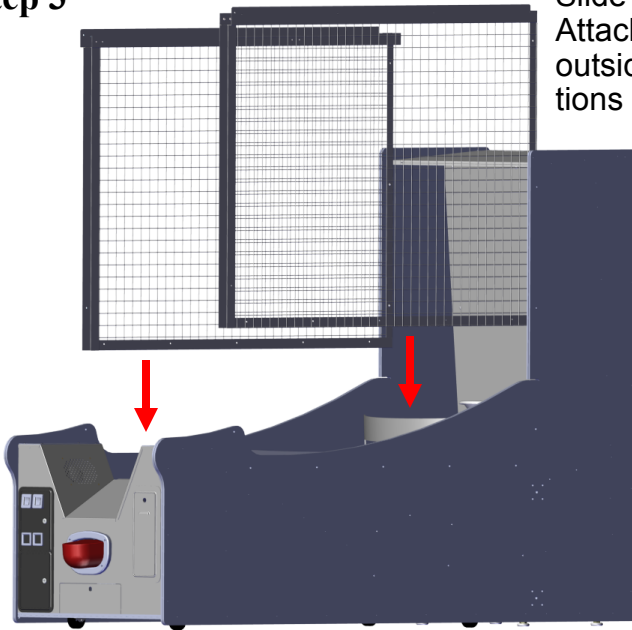

Using one hat nut on the outside and the shorter 1/4-20 Allen on the inside . A tool is provided in the parts package.

DO NOT TIGHTEN AT THIS TIME.

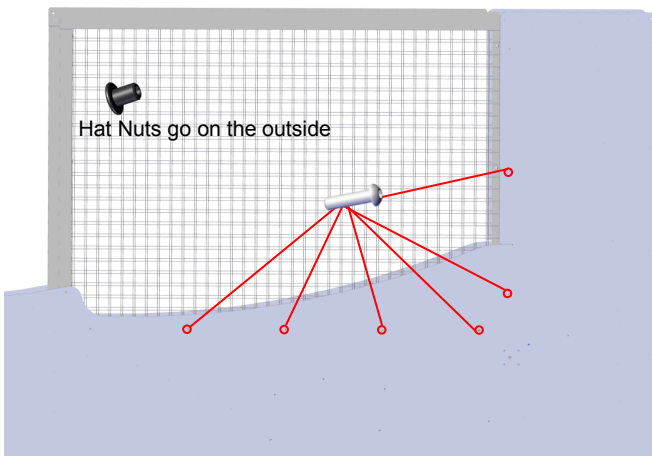

Now install the remaining hat nuts and 1/4-20 bolts.

DO NOT TIGHTEN UNTIL EVERY BOLT HAS BEEN INSTALLED.

This will allow you to align the cage better.

Now tighten all bolts.

Step 4

Attach the upper support and the proximity sensor to the cabinet using two 1/4-20 bolts on each side.

The proximity sensor can be found in the parts package located in the cash box. Be sure to angle the sensor so that it points to the Milk Jug which should be about a 45 degree angle.

DO NOT PLUG SENSOR HARNESS INTO SENSOR WITH GAME POWER APPLIED. DAMAGE MAY OCCUR TO SENSOR.

The bolts are attached from the inside as shown in the circles. Attach the sensor wire harness to the sensor. The path of the wire should travel along the front left channel.

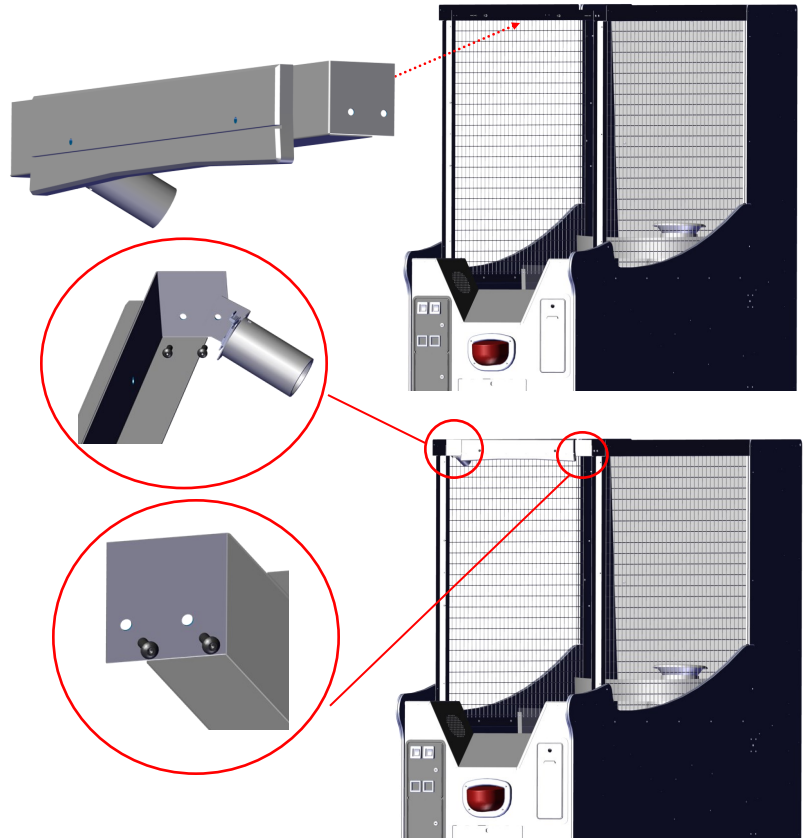

Step 5

Run the proximity sensor harness inside down the left side of the front cage channel and attach the plastic trim on both sides. Attach the two plates with the square screws to cover the center trim.

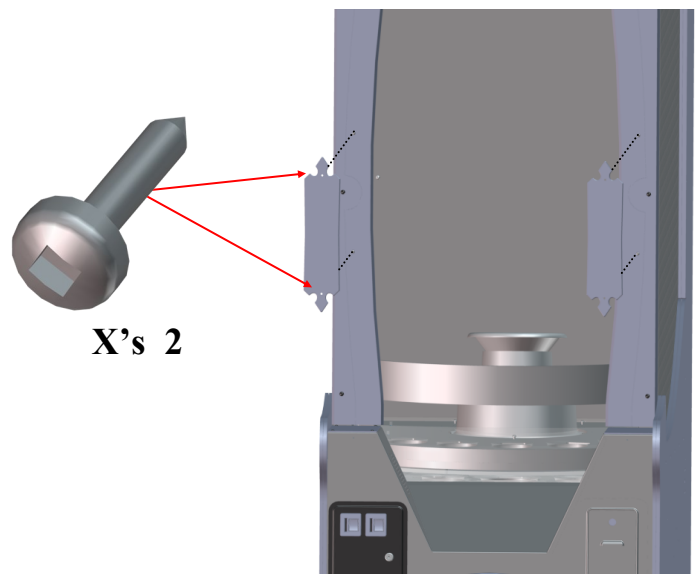
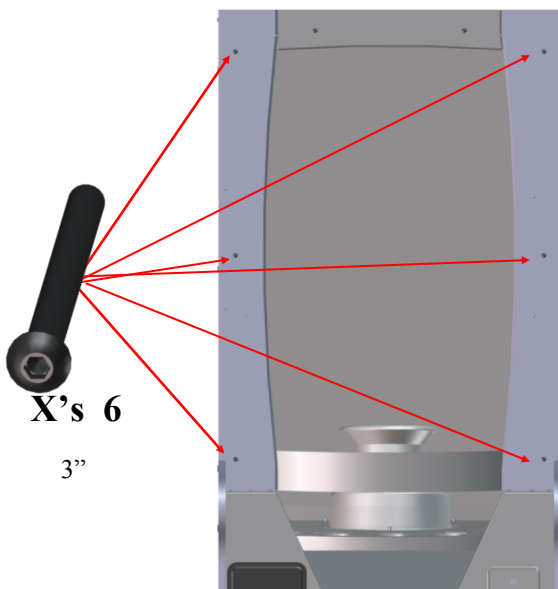

Step 6:

Remove ties that hold the upper supports to the shipping 2x4 and lift the upper supports up.

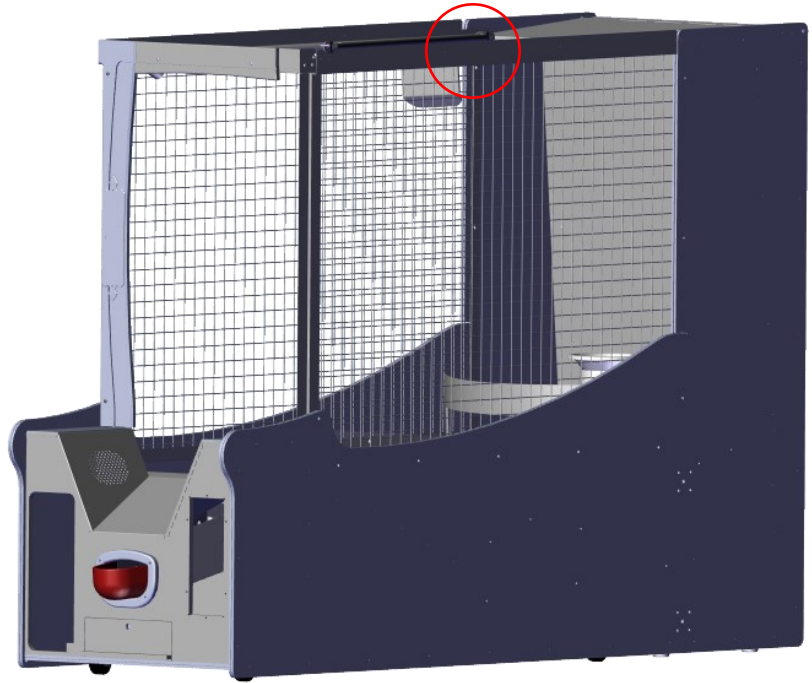

Step 7:

Raise the bars to their upright position.

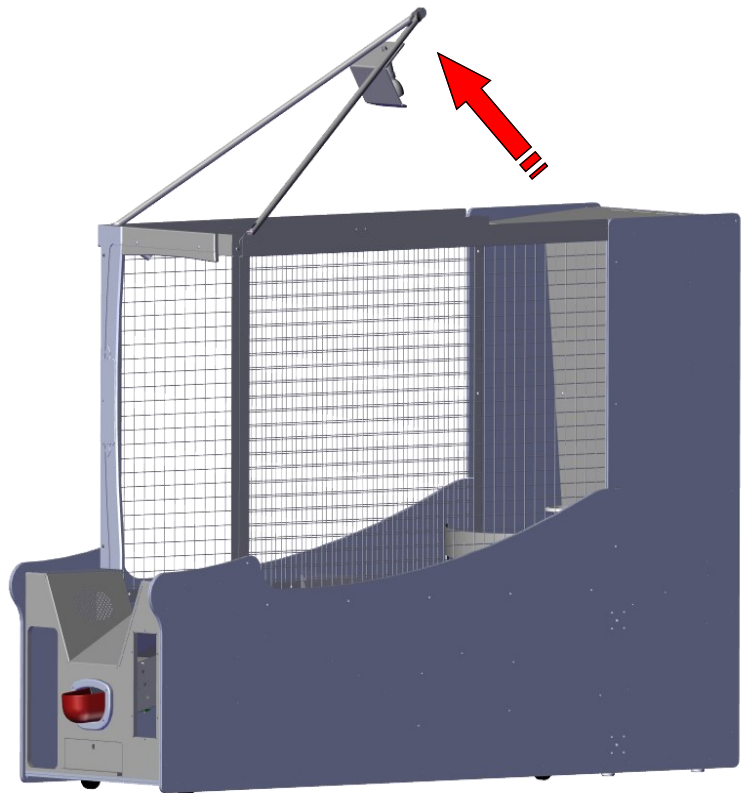

Step 8:

Attach the upper back supports to the front back supports using the supplied hardware as shown. At this time attach the earth ground wire to the grounding lug at the light. Connect the AC harness for the light fixture. Tighten all hardware. It is recommended to use a long extension when attach the Allen bolts.

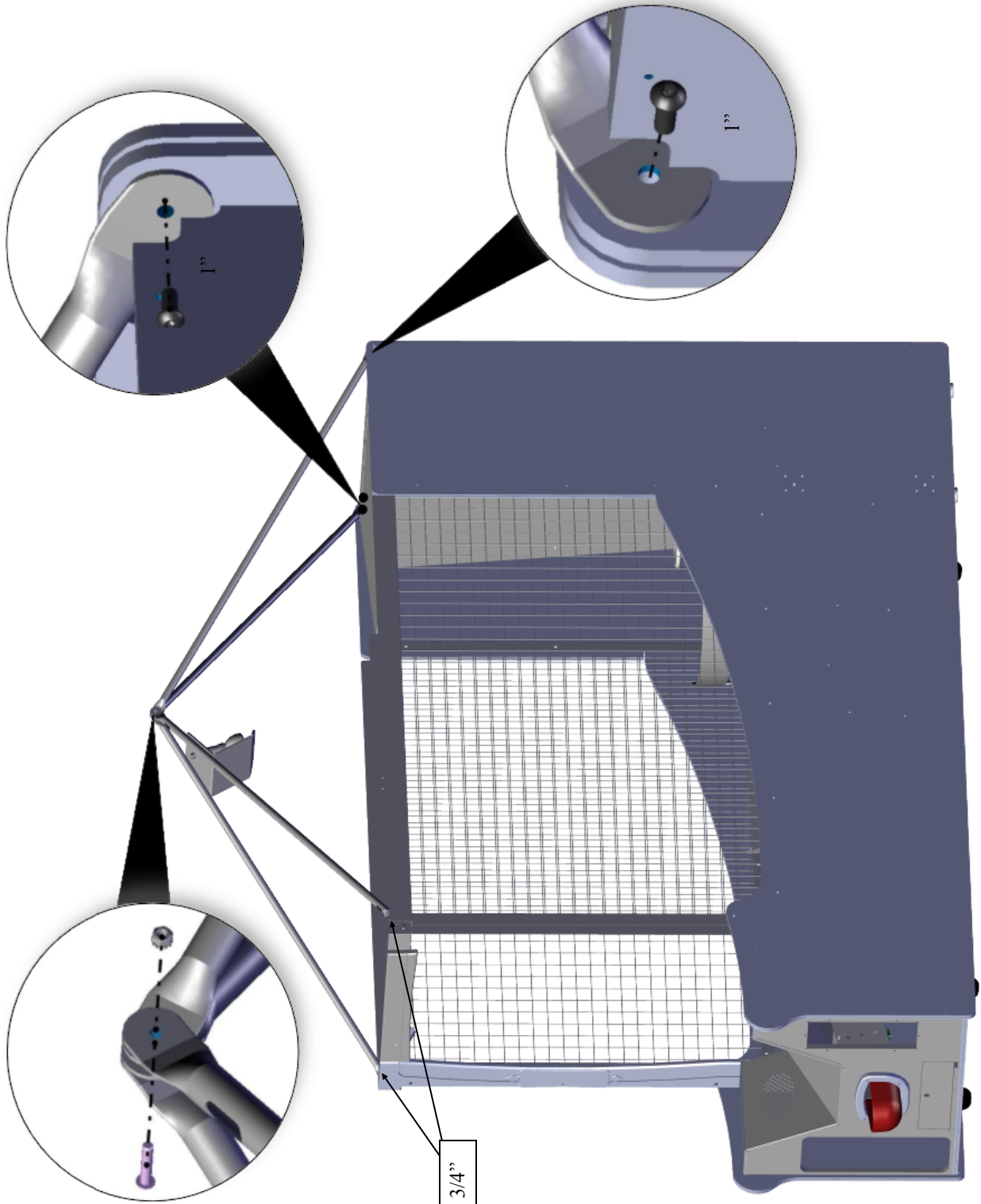

Step 9:

Before proceeding it is recommended to apply the decals to this before installing. See page 18 for recommended settings. Attach the upper bonus Jug sign using the self tapping Robinson screws following the predrilled holes shown below.

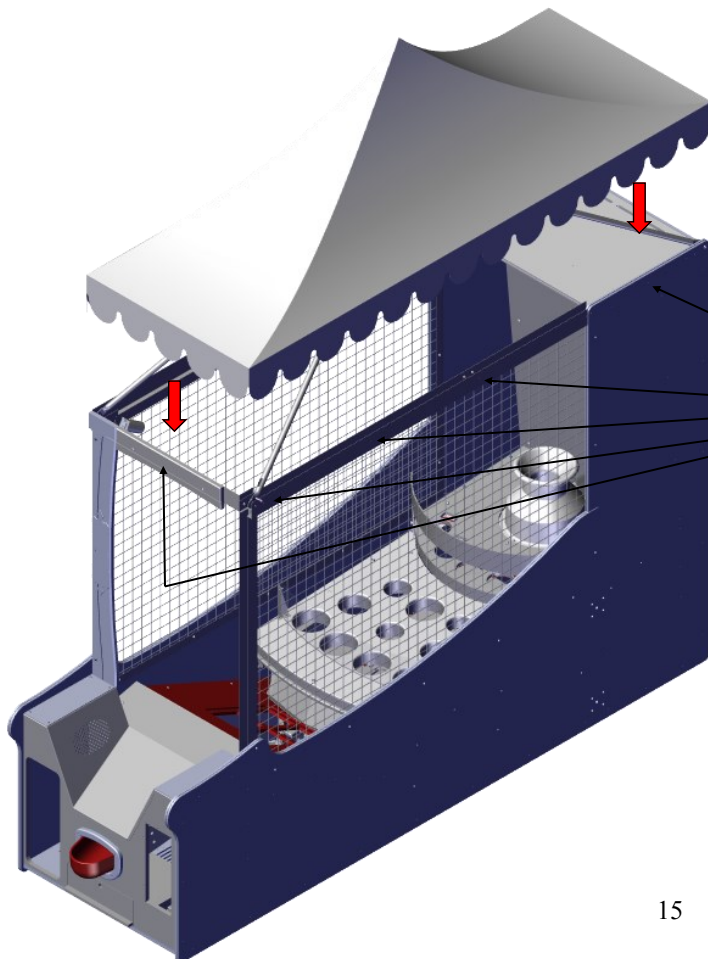
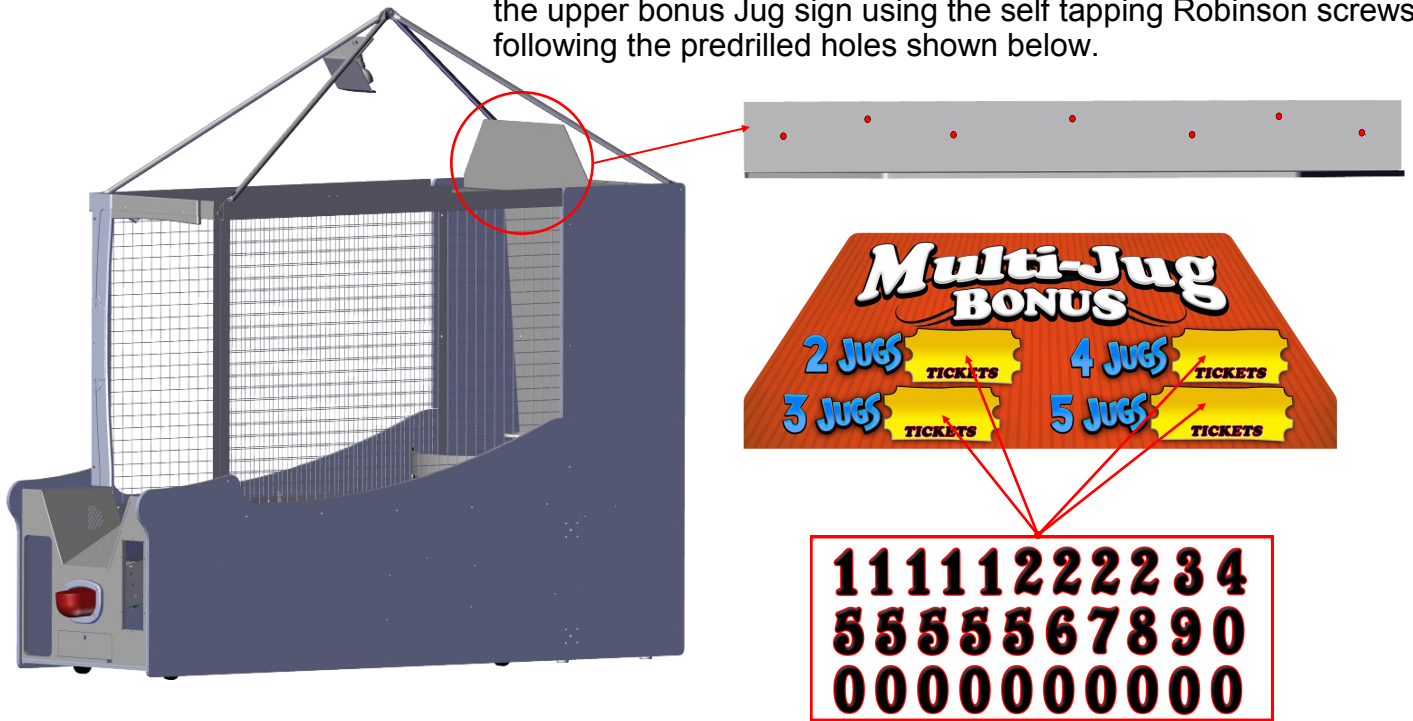

Step 10:

Attach the upper marquee using the self tapping Robinson screws following the arrows shown. Only one side is shown for clarity.

Step 11:

Finally raise the back end of the game by twisting the back leg levers counter-clockwise. It is important not to have the game totally leveled but instead, have the back slightly raised enough so that the balls can return to the conveyor easier. If you find that your balls are getting hung up when returning to the conveyor, you do not have the back raised enough.

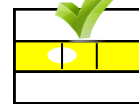
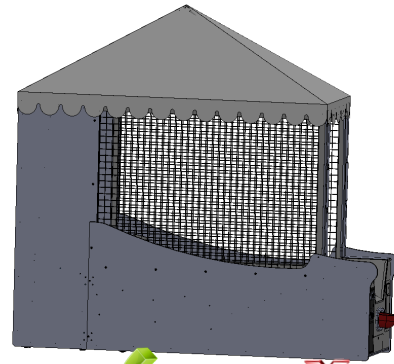
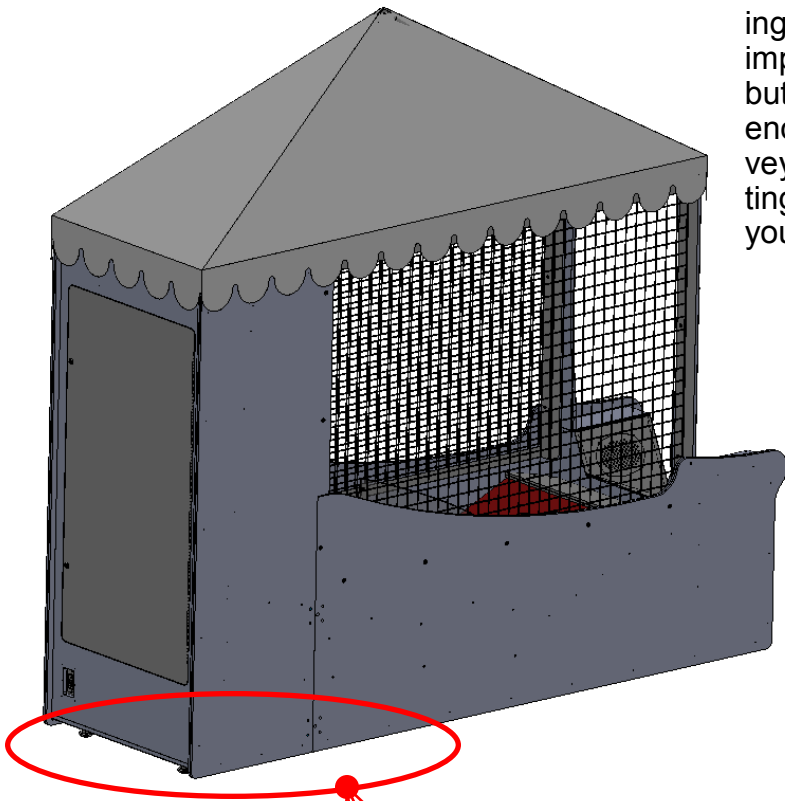

NOT LEVEL

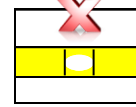

LEVEL

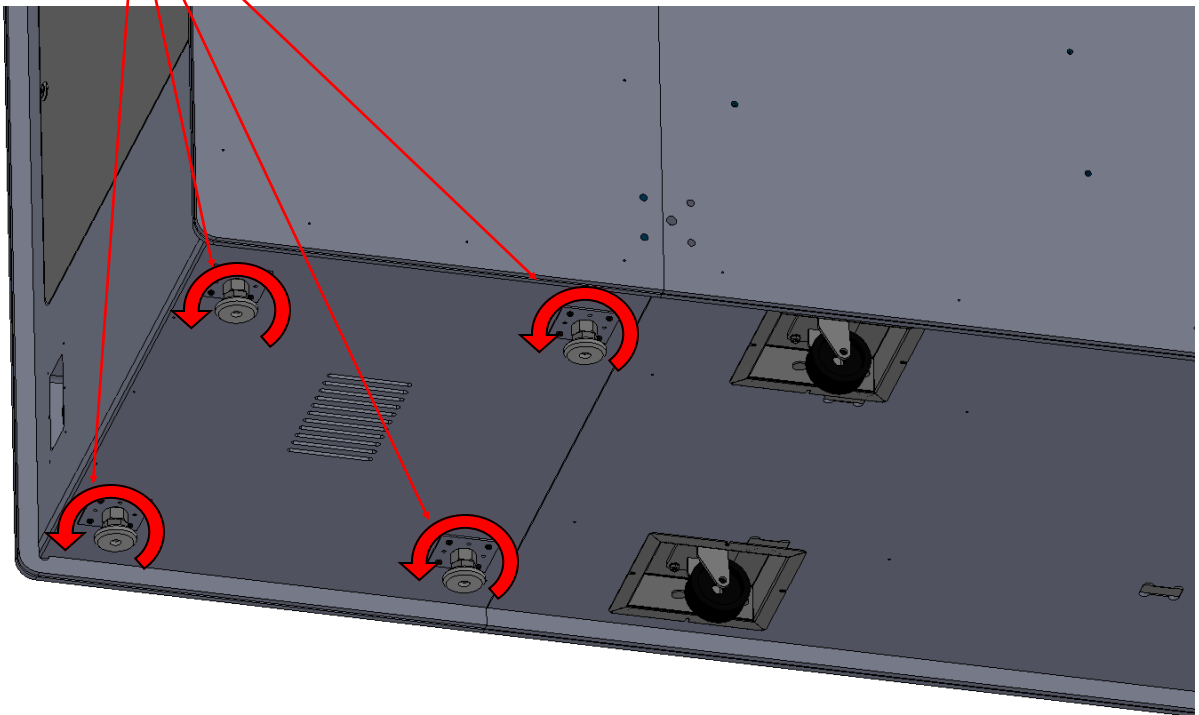

If installing a marquee, see “Optional Marquee Installation”.

Optional Marquee Installation

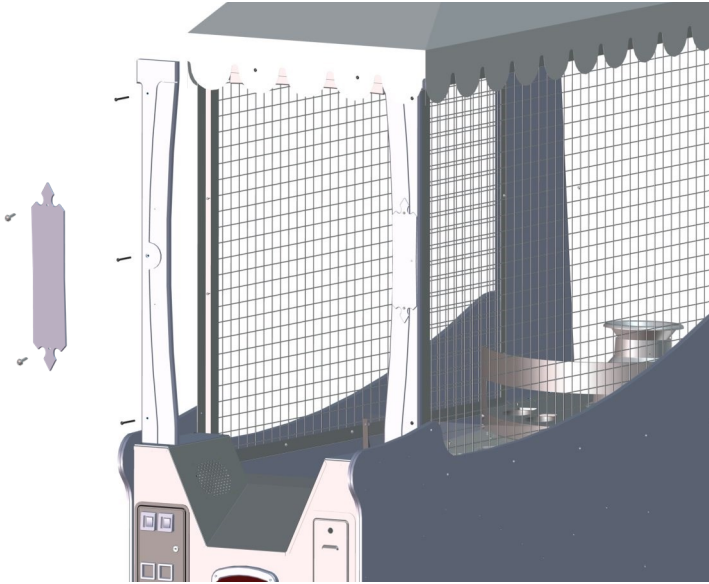

Step 1:

Remove the left side display plate and then the plastic trim from the front of the game. Do not discard the three bolts. Do not discard the display Plate. Discard the 2 Square bit screws as they are not needed.

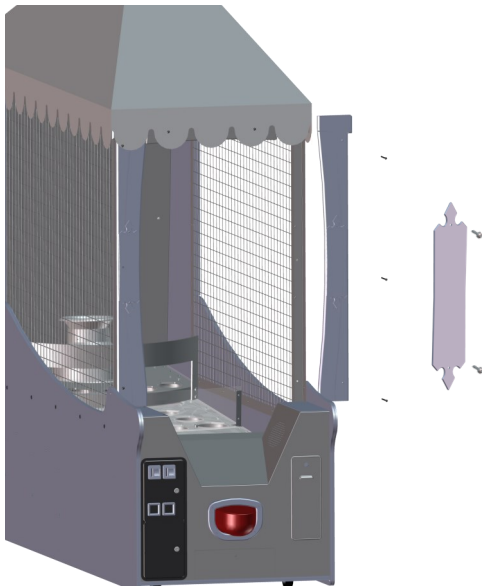

Step 2:

On the second game remove the right side display plate and plastic trim piece from the front of the game. Do not discard the three Allen bolts. Do not discard the display Plate.



Step 3:

Attach one of the L-shaped spacers to the left side of a game using four 1 1/2" wood screw and the other L-shaped spacer to the right side of the other game. Mount the spacer flush to the outside of the cabinet. No spacer is used in back of game.

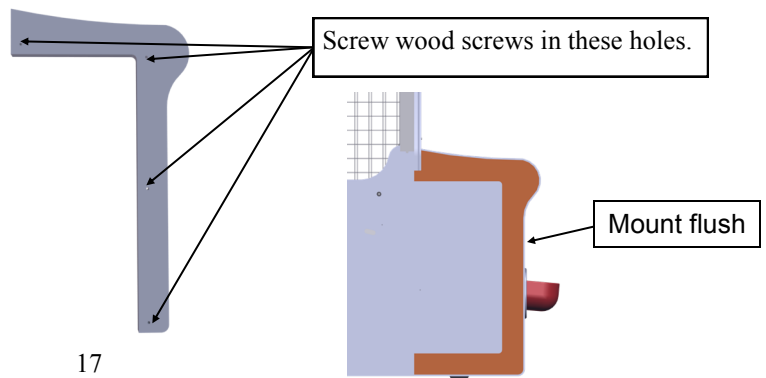
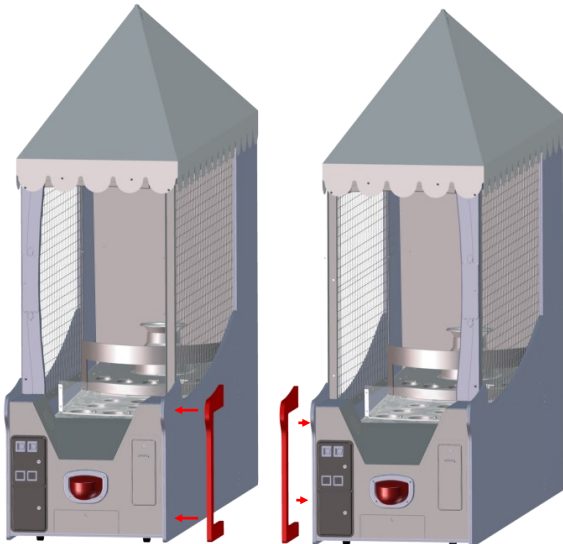

Optional Marquee Installation

Step 4:

Drill a one inch hole on the same side that you attached a spacer to if your game doesn't have a hole already present. You may have to pull the star decal back to confirm the present of the hole. This hole is used to route the phone cord that is installed later on. Refer below for measurements.

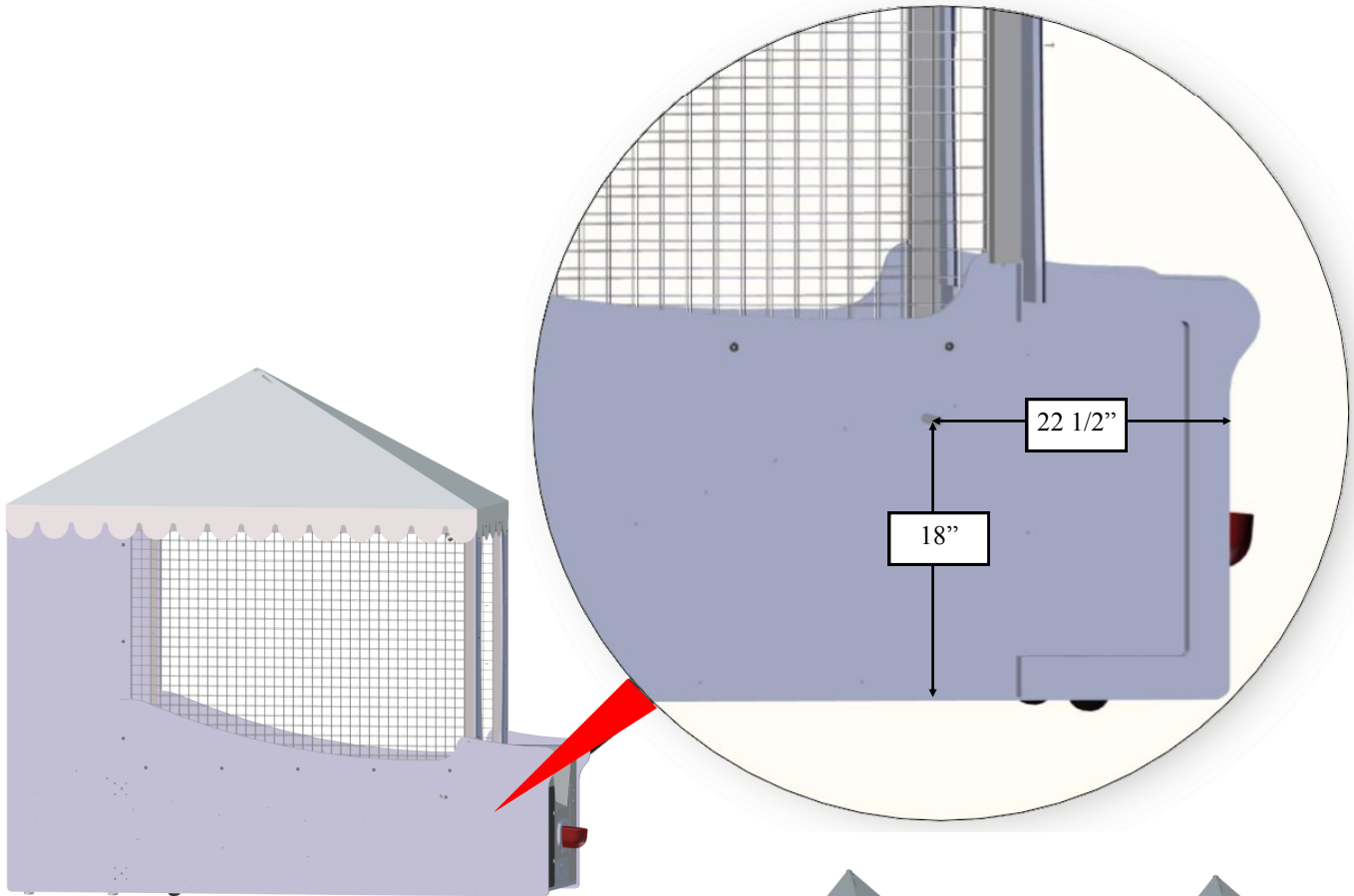

Step 5:

Position the two games as shown and slide the two games together. It is not critical that the games be 100% parallel to each other, they can be off at the back by up to a few inches. The front needs to be flush in order for the marquee mount to attach properly. Both games need to be at the same level in front.

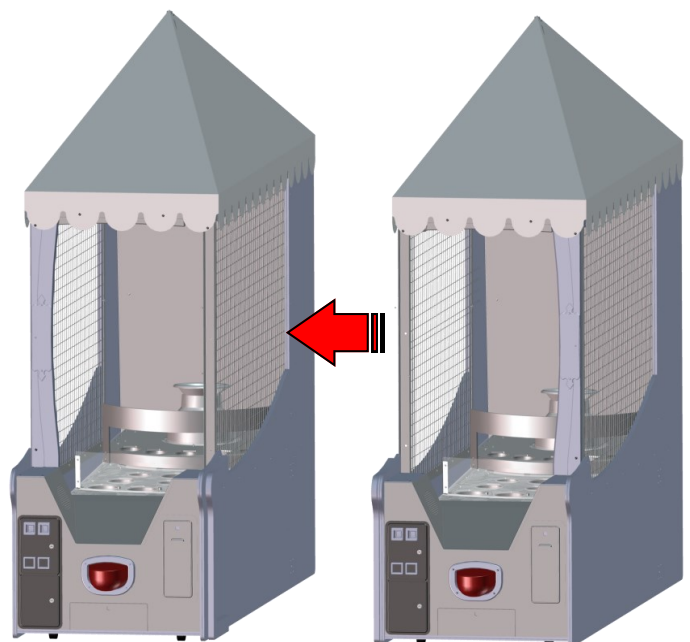

Optional Marquee Installation

Step 6a:

Place the marquee assembly so that the bottom groove is at an angle as shown below. The fit is tight and will require a little force to bring the games into alignment. Once the marquee assembly is firmly resting at the bottom of the groove, push the top flush with the cabinet. Before fully resting the marquee against the cabinet, insert the canopy side flaps into the slots circled below at the top of the plastic face. Do not pinch the canopy flaps behind the marquee. It will result in a unfinished look. Also pay attention to the wire harnesses so that you do not pinch them against the cabinet cages.

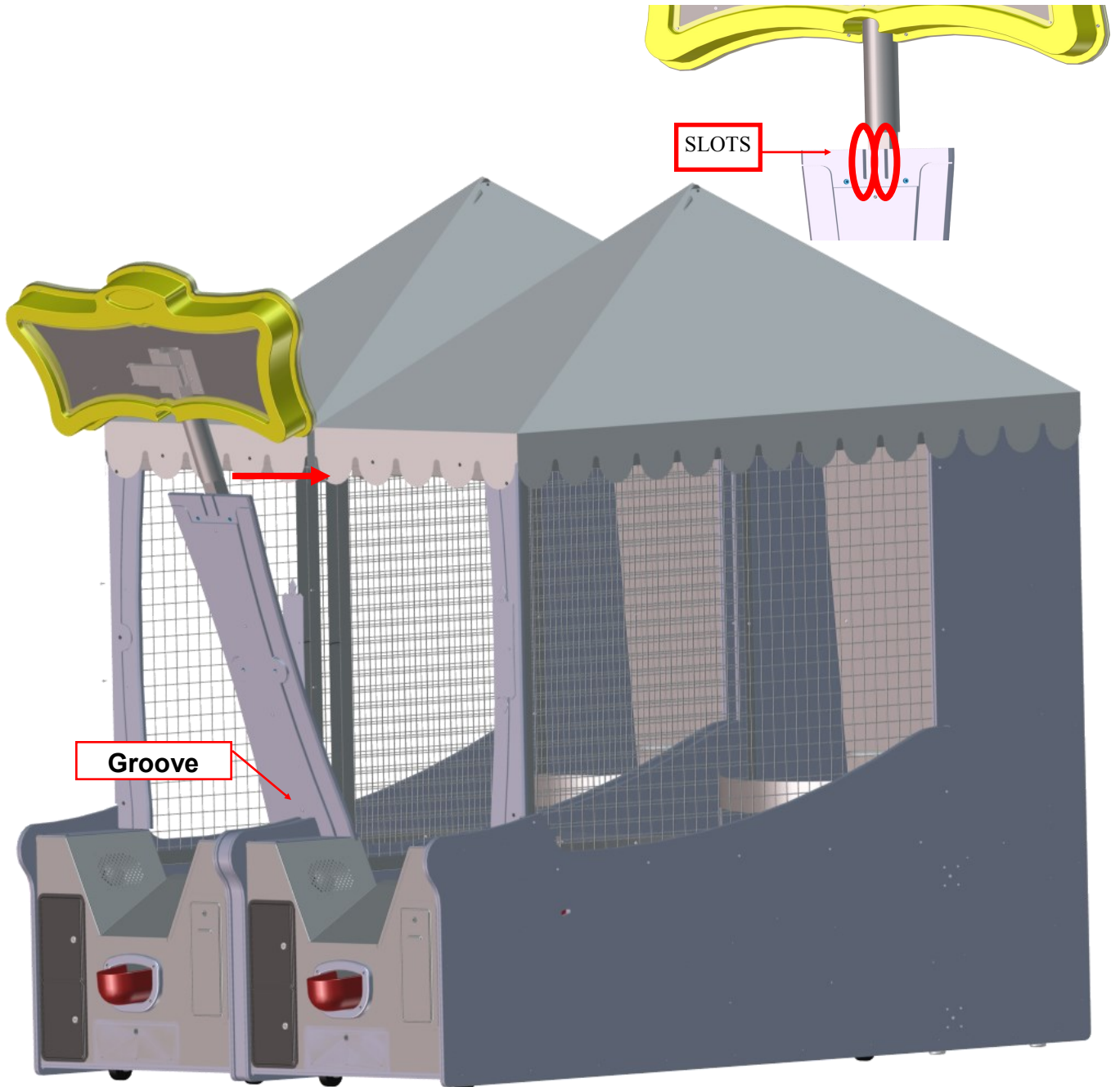

Optional Marquee Installation

Step 6b:

Attach the marquee to the cabinet using the bolts you had removed in step 1. The bolt locations are circled below. Re-attach one display plate you took off in steps 1 or 2 of "Optional Marquee Installation". Use the two 8-32 x1 " PPHMS screws supplied to attach the plate.

See "DECAL INSTALL LOCATIONS" to pick your plate decal if blank.



Optional Marquee Installation

Step 7:

Route the wire harness from the marquee to the left game through the cage as shown in the picture. Drop the wires down the hole shown with the arrow. Use a wire tie to attach the harness to the cage. Now run a phone cord from the left game's main board to the right game's main board through the hole in step 4. Open the bottom drawer to access the main board. It doesn't matter which phone connector you use, they are both the same.

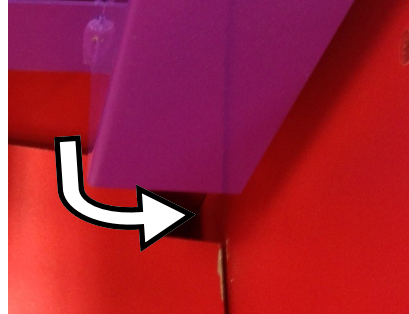
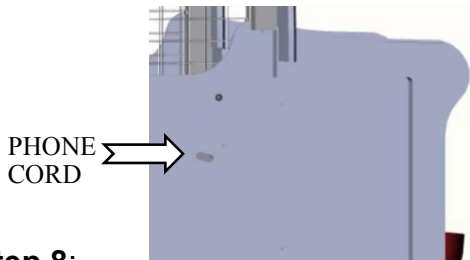

Step 8:

Remove the two Allen bolts shown below and remove the cover on both games. Located at the right of the game is the AC plug, and in some units the data display plug for the marquee. See the picture below, they are circled. Refer to the wiring schematic insert for further harness information.

NOTE: BOTH GAMES MUST BE SETUP EXACTLY THE SAME IN PROGRAMMING. EVEN THOUGH THEY ARE LINKED THEY DO NOT SHARE INFORMATION BETWEEN EACH OTHER.

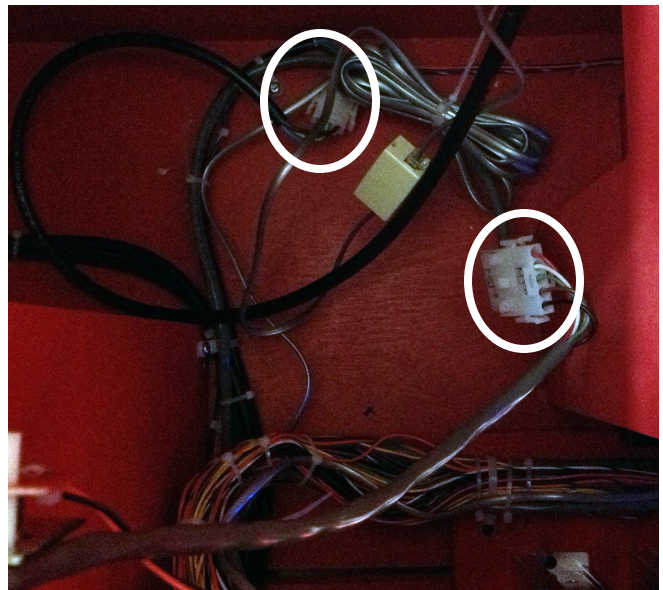
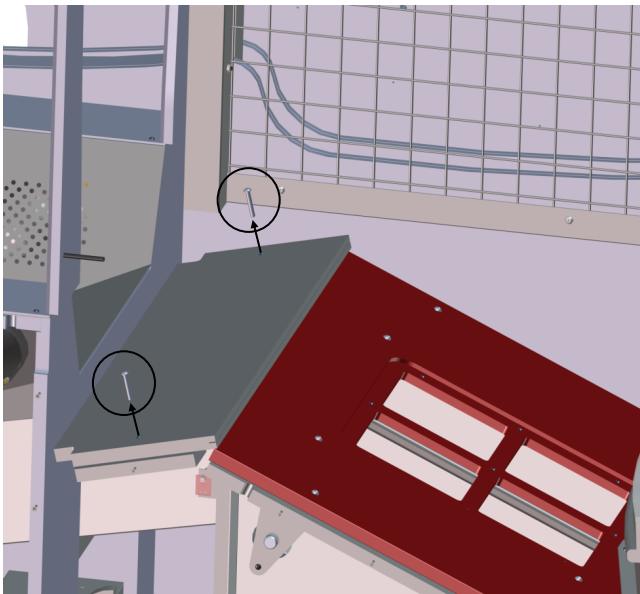

Decal Install locations

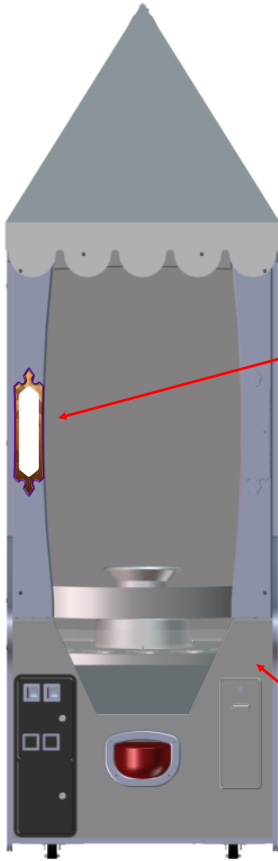

Choose the decal that best suits your taste.

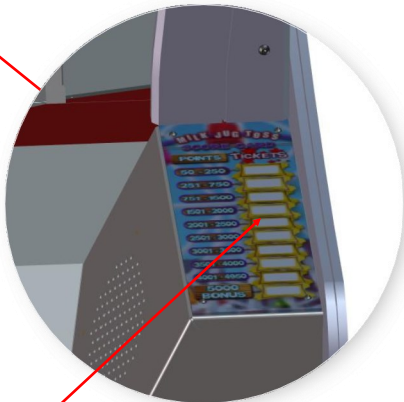

25 cent game 50 cent game \$1.00 game

| | | |
|------------|------------|-------------|
| 2 | 3 | 5 |
| 3 | 5 | 10 |
| 4 | 10 | 25 |
| 5 | 15 | 40 |
| 10 | 25 | 50 |
| 15 | 30 | 75 |
| 25 | 50 | 100 |
| 50 | 75 | 250 |
| 100 | 250 | 500 |
| 250 | 500 | 1000 |

Use the correct decal for the amount of money you wish to charge. You will need to adjust your software settings to match the values you use here. Refer to the next few pages for further information.

SETUP - Game Options, Audits, and Meters.

To access either the game options or perform the game audits, open the upper coin door as shown below and press the “PROG” button to enter game options or press the “DOWN” button to enter game audits.

In Game Options:

The how many balls are left display shows which option you are currently on. The score display shows the current value for that option. Pressing the UP or DOWN buttons will either increase or decrease the options’ value. Pressing the “SELECT” button will go to the next option. To exit and save changes press the “PROG” button. See page 24 for a list of options and descriptions.

In Audit mode:

The game will display in the points display how many times that sensor has been scored. The how many balls left display tells you the sensor number. If a light is available for that sensor it will also light. See page 26 for more details.

The coin meter and ticket meter is also located in the upper coin door.

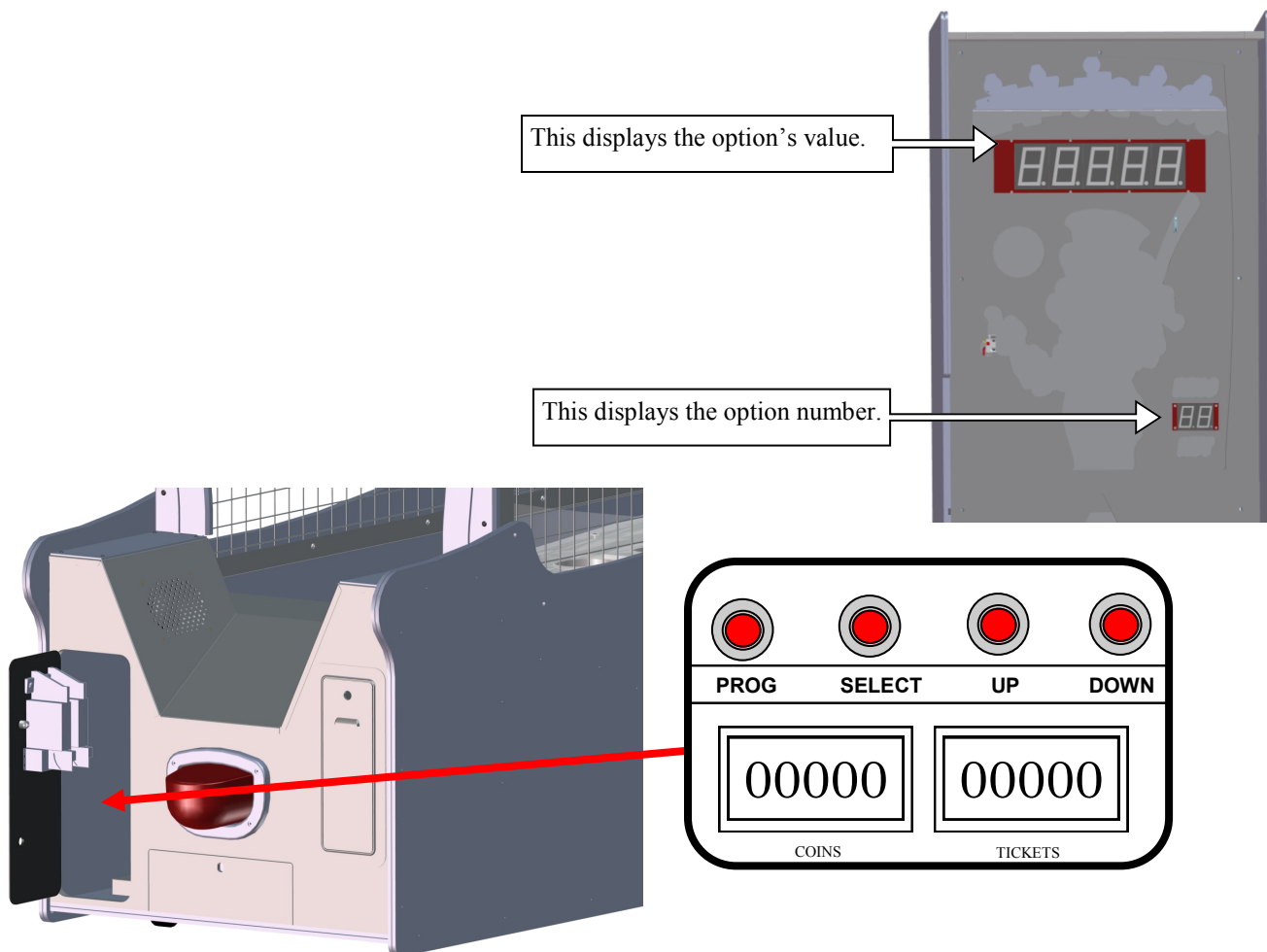

Programming Options for Milk Jug Rev 3.20

| Option | | Default | Min | Max | Inc | |
|---|------------------------|---------|-----|------|-----|-------------------------------------|
| 0 | Game Volume | 5 | 0 | 7 | 1 | Game sounds |
| 1 | Music Volume | 3 | 0 | 7 | 1 | Music sounds |
| 2 | Coin 1 | 2 | 0 | 10 | 1 | Cost of Game |
| This tells the game how many pulses to start a game | | | | | | |
| 3 | Coin 2 | 1 | 0 | 10 | 1 | # of Coin 1's |
| 4 | DBV | 4 | 0 | 10 | 1 | # of Coin 1's |
| These are multiplier lines, setting them to a value will give that many pulses on that line when triggered | | | | | | |
| 5 | Discount | 0 | 0 | 10 | 1 | # of Games til +1 |
| Determines how many games in a row needed to be purchased for a free game. 0 = disabled. | | | | | | |
| 6 | Minimum Tickets option | 1 | 0 | 20 | 1 | MTO Tickets |
| Game will pay out at least this many tickets if a value is set. | | | | | | |
| 7 | Attract Time | 1 | 0 | 90 | 1 | Attract time |
| 8 | Jug 1 Bonus | 10 | 0 | 100 | 1 | Bonus Tickets |
| 9 | Jug 2 Bonus | 25 | 0 | 250 | 1 | Bonus Tickets |
| 10 | Jug 3 Bonus | 50 | 0 | 500 | 5 | Bonus Tickets |
| 11 | Jug 4 Bonus | 250 | 0 | 1000 | 10 | Bonus Tickets |
| 12 | Jug 5 Bonus | 500 | 0 | 5000 | 50 | Bonus Tickets |
| Options 7-12 sets how many tickets you win by getting xx jugs. | | | | | | |
| 13 | Points 0-250 | 3 | 0 | 100 | 1 | Points to Tickets |
| 14 | Points 251-750 | 5 | 0 | 100 | 1 | Points to Tickets |
| 15 | Points 751-1500 | 10 | 0 | 100 | 1 | Points to Tickets |
| 16 | Points 1501-2000 | 15 | 0 | 100 | 1 | Points to Tickets |
| 17 | Points 2001-2500 | 25 | 0 | 250 | 1 | Points to Tickets |
| 18 | Points 2501-3000 | 30 | 0 | 250 | 1 | Points to Tickets |
| 19 | Points 3000-3500 | 50 | 0 | 1250 | 5 | Points to Tickets |
| 20 | Points 3501-4000 | 75 | 0 | 1250 | 5 | Points to Tickets |
| 21 | Points 4001-4950 | 250 | 0 | 1250 | 5 | Points to Tickets |
| 22 | Points 5000 | 500 | 0 | 2500 | 10 | Points to Tickets |
| Options 13 - 22 determines how many tickets you win for xx points scored. | | | | | | |
| 23 | Timeout of Balls | 30 | 30 | 60 | 1 | Timeout in Seconds |
| ** Option 23 will add 50 points to the score when it doesn't see a ball thrown. ** | | | | | | |
| 24 | Bonus Type | 0 | 0 | 1 | 1 | 0=Bonus or Score 1=Score + Bonus |
| If set for 0 players win either jug tickets or score tickets (whichever is higher) or jug tickets and score tickets combined if set to 1. | | | | | | |
| 25 | Factory Reset | 0 | 0 | 1 | 1 | Factory Reset |
| This option will reset the game to factory defaults and clears all audits. | | | | | | |

SEE NEXT PAGE FOR RECOMMENDED SETTINGS

25 cent

| MILK JUG TOSS SCORE CARD | |
|--------------------------|---------|
| POINTS | TICKETS |
| 50 - 250 | 2 |
| 251 - 750 | 3 |
| 751 - 1500 | 4 |
| 1501 - 2000 | 5 |
| 2001 - 2500 | 10 |
| 2501 - 3000 | 15 |
| 3001 - 3500 | 25 |
| 3501 - 4000 | 50 |
| 4001 - 4950 | 100 |
| 5000 BONUS | 250 |

50 cent

| MILK JUG TOSS SCORE CARD | |
|--------------------------|---------|
| POINTS | TICKETS |
| 50 - 250 | 3 |
| 251 - 750 | 5 |
| 751 - 1500 | 10 |
| 1501 - 2000 | 15 |
| 2001 - 2500 | 25 |
| 2501 - 3000 | 30 |
| 3001 - 3500 | 50 |
| 3501 - 4000 | 75 |
| 4001 - 4950 | 250 |
| 5000 BONUS | 500 |

75 cent

| MILK JUG TOSS SCORE CARD | |
|--------------------------|---------|
| POINTS | TICKETS |
| 50 - 250 | 5 |
| 251 - 750 | 10 |
| 751 - 1500 | 15 |
| 1501 - 2000 | 20 |
| 2001 - 2500 | 25 |
| 2501 - 3000 | 50 |
| 3001 - 3500 | 75 |
| 3501 - 4000 | 100 |
| 4001 - 4950 | 250 |
| 5000 BONUS | 500 |

\$1.00

| MILK JUG TOSS SCORE CARD | |
|--------------------------|---------|
| POINTS | TICKETS |
| 50 - 250 | 5 |
| 251 - 750 | 10 |
| 751 - 1500 | 25 |
| 1501 - 2000 | 40 |
| 2001 - 2500 | 50 |
| 2501 - 3000 | 75 |
| 3001 - 3500 | 100 |
| 3501 - 4000 | 250 |
| 4001 - 4950 | 500 |
| 5000 BONUS | 1000 |

Multi - Jug Values

2 Jugs 50

3 Jugs 100

4 Jugs 500

1000
5 Jugs

Multi - Jug Values

2 Jugs 25

3 Jugs 75

4 Jugs 250

500
5 Jugs

Multi - Jug Values

2 Jugs 25

3 Jugs 50

4 Jugs 250

500
5 Jugs

Multi - Jug Values

0

10

25

100

250

With average skilled players your payout will be around 30% to 35%

Milk Jug Accounting Version 3.20

Milk Jug accounting is entered by pressing the far right (down) button when NOT in programming mode. The game will cycle through each of the different locations and will wrap to the beginning. To zero the values press the third button (up) as counting from the left. When zeroed the game should exit accounting to signify that you have zeroed the values. To exit without zeroing the values press the same button used to enter into accounting mode.

Most locations will flash where the value showing is coordinated with. The numbers are from bottom left to top right and then Jug, etc.

| Number | Locations |
|---------------|---|
| 1 | Lower Playfield Left (50) |
| 2 | Lower Playfield Second from Left (50) |
| 3 | Lower Playfield Second from Right (50) |
| 4 | Lower Playfield Right (50) |
| 5 | Lower Playfield Middle Row Left (100) |
| 6 | Lower Playfield Middle Row Middle (250) |
| 7 | Lower Playfield Middle Row Right (100) |
| 8 | Lower Playfield Top Row Left (150) |
| 9 | Lower Playfield Top Row Middle (50) |
| 10 | Lower Playfield Top Row Right (150) |
| 11 | Upper Playfield Left (200) |
| 12 | Upper Playfield Second from Left (250) |
| 13 | Upper Playfield Middle (300) |
| 14 | Upper Playfield Second from Right (250) |
| 15 | Upper Playfield Right (200) |
| 16 | Jug (1000) |
| 17 | Zero Jug Games |
| 18 | One Jug Games |
| 19 | Two Jug Games |
| 20 | Three Jug Games |
| 21 | Four Jug Games |
| 22 | Five Jug Games |
| 23 | Tilted Games |

NOTE:

To prevent hiccups in the game the results of the game are stored when the game is idle. If there are constant credits in the game then the above values will not be able to store into non-volatile memory and will be lost if power is removed. So to insure that all values are saved the game should be in attract for 20 seconds.

For a quick check of sensors, any value at 0 should be checked.

Milk Jug Error Codes Version 3.20

| <u>Error</u> | <u>Reason</u> | <u>Halt Game</u> |
|--------------|----------------------------|------------------|
| 1 | Ticket Error | N |
| 2 | Compact Flash Error | N |
| 3 | Error Sensor Hole 1 | N |
| 4 | Error Sensor Hole 2 | N |
| 5 | Error Sensor Hole 3 | N |
| 6 | Error Sensor Hole 4 | N |
| 7 | Error Sensor Hole 5 | N |
| 8 | Error Sensor Hole 6 | N |
| 9 | Error Sensor Hole 7 | N |
| 10 | Error Sensor Hole 8 | N |
| 11 | Error Sensor Hole 9 | N |
| 12 | Error Sensor Hole 10 | N |
| 13 | Error Sensor Hole 11 | N |
| 14 | Error Sensor Hole 12 | N |
| 15 | Error Sensor Hole 13 | N |
| 16 | Error Sensor Hole 14 | N |
| 17 | Error Sensor Hole 15 | N |
| 18 | Jug Sensor 1 | Y |
| 19 | Jug Sensor 2 | Y |
| 20 | Ball Dispense Sensor Front | Y |
| 21 | Ball Dispense Count | N |
| 22 | Left Zero Sensor | N |
| 23 | Coin 1 Switch stuck | N |
| 24 | Coin 2 Switch stuck | N |
| 25 | DBV Switch stuck | N |
| 26 | - Not Used - | - |
| 27 | Cheat Sensor 1 stuck | - |
| 28 | Right Zero Sensor | N |
| 29 | Program button stuck | N |
| 30 | Select button stuck | N |
| 31 | Up button stuck | N |
| 32 | Down button stuck | N |

Upon power up the error codes will cycle for 5 loops displaying any error codes that are currently active. The game will then continue on, unless a Jug error code exists.

**** The high score display will show a 2000 as its current highest score if a error is detected on power up.**

**** A high score of 1050 means the game has just been powered on or has rebooted.**

Score Sensor Layout

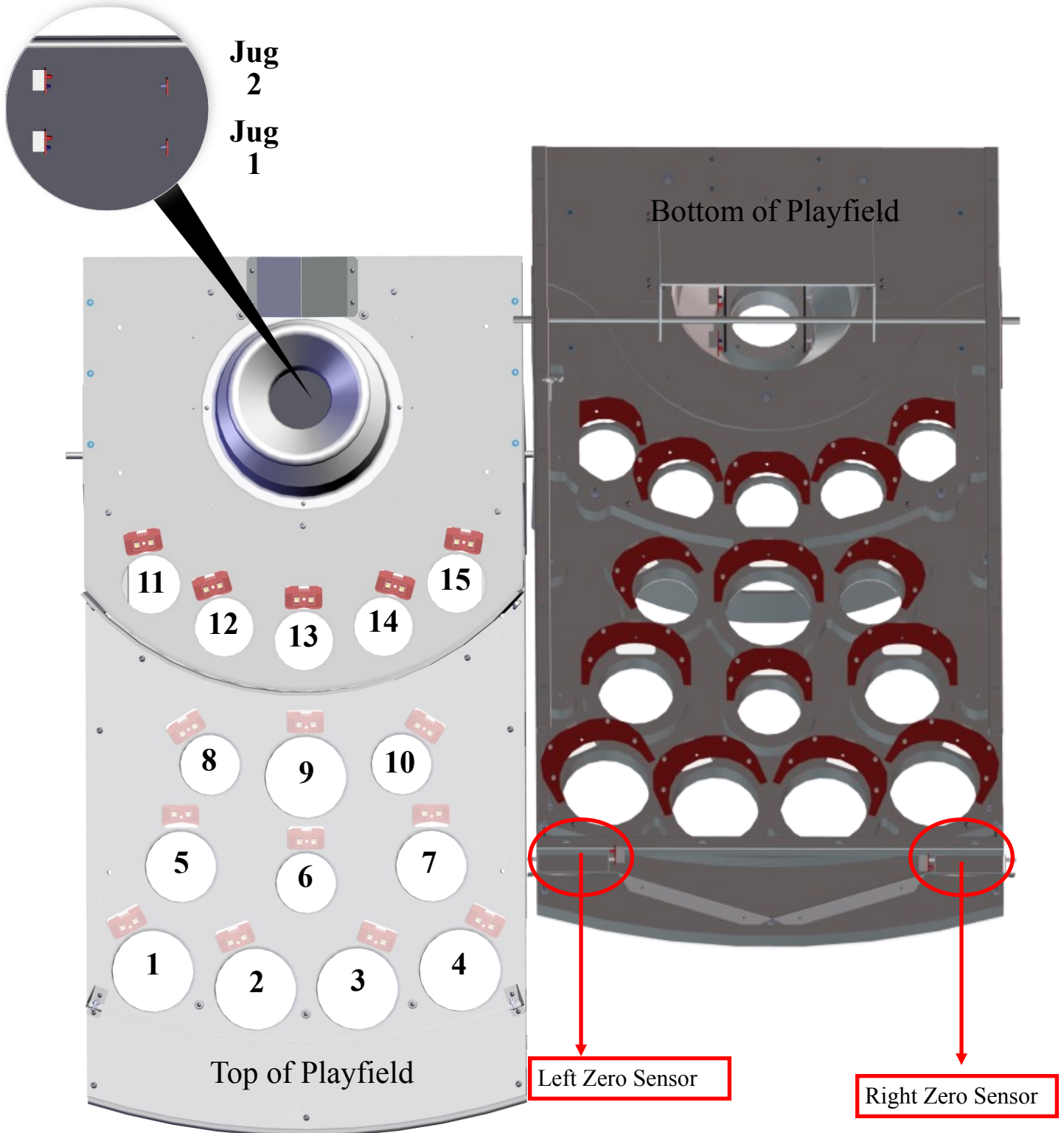

Playfield Service

The playfield flips open for easy access to all score sensors and it is also how you access the illegal ball trap door.

Remove the two hat bolts shown below using a Allen wrench. **** WARNING**** Be sure that no persons fingers finger's are holding onto the side cages when raising or lowering the playfield. Lift the playfield all the way as far as it will go, the shocks will keep the playfield up in the air during servicing.

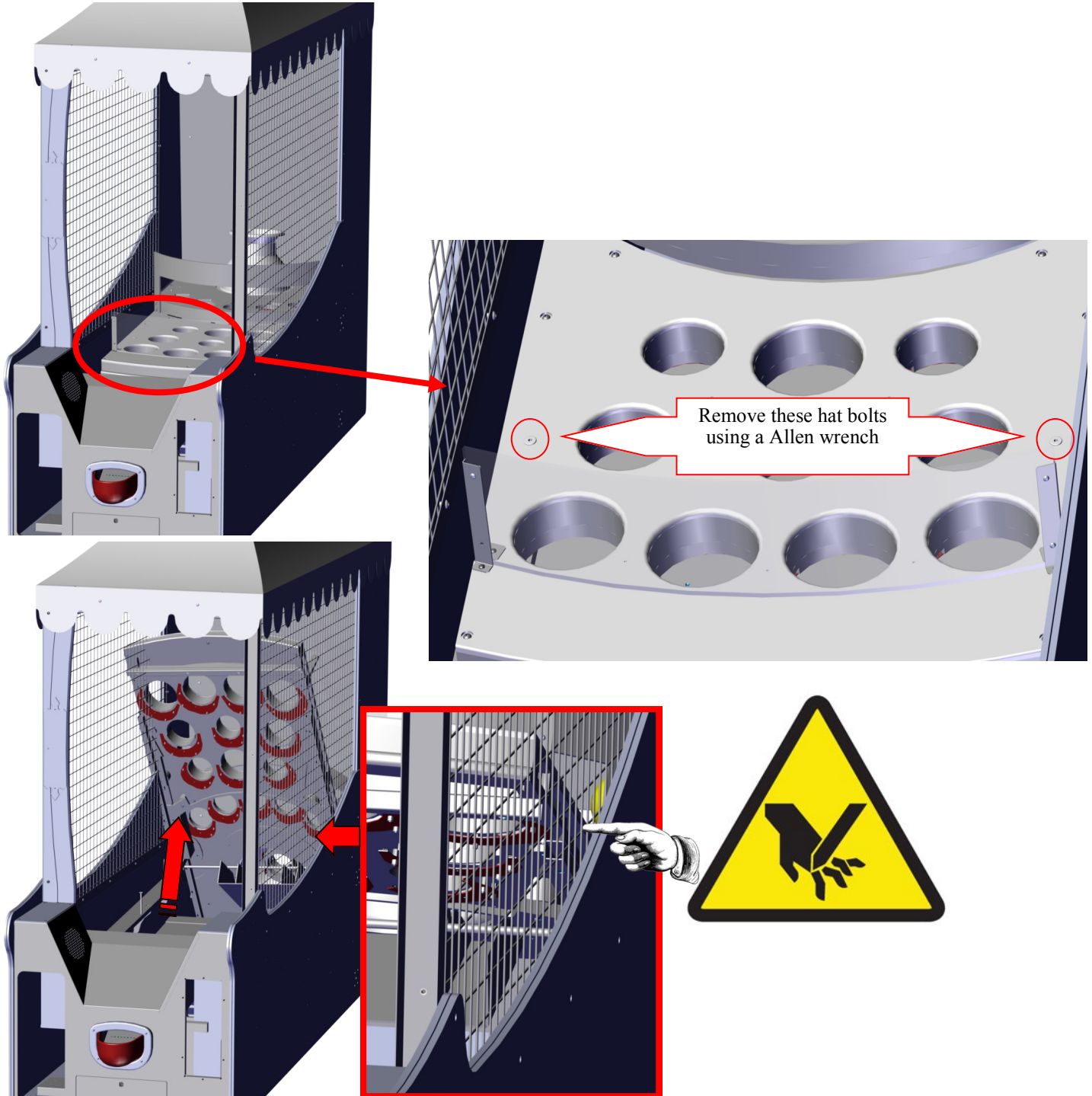

Illegal Ball Size Access Door

During game play if any balls used is not of the correct size it will fall into the games' "illegal ball trap" storage located under the playfield. To access this and remove the balls, follow the instructions in the section titled "Play field Service". Using your keys, unlock the plastic cover and remove. You can now remove the balls. Replace cover and close the playfield. The diagram below shows the cover. Side of cabinet removed for clarity.

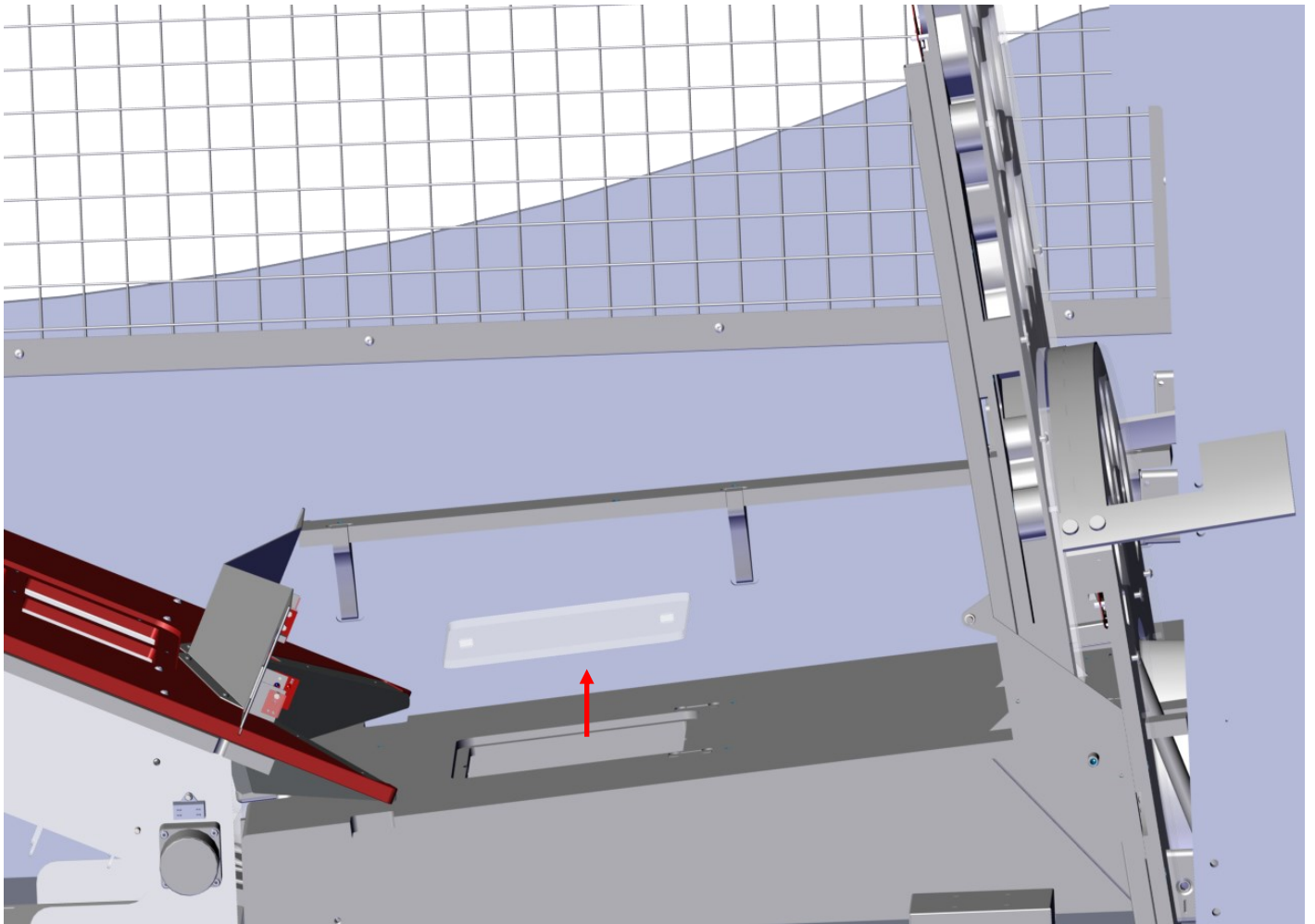

Accessing the Main Board and Power Supply

To gain access to the main board, open the bottom door and pull the drawer out. There you will find the main circuit board and power supply.

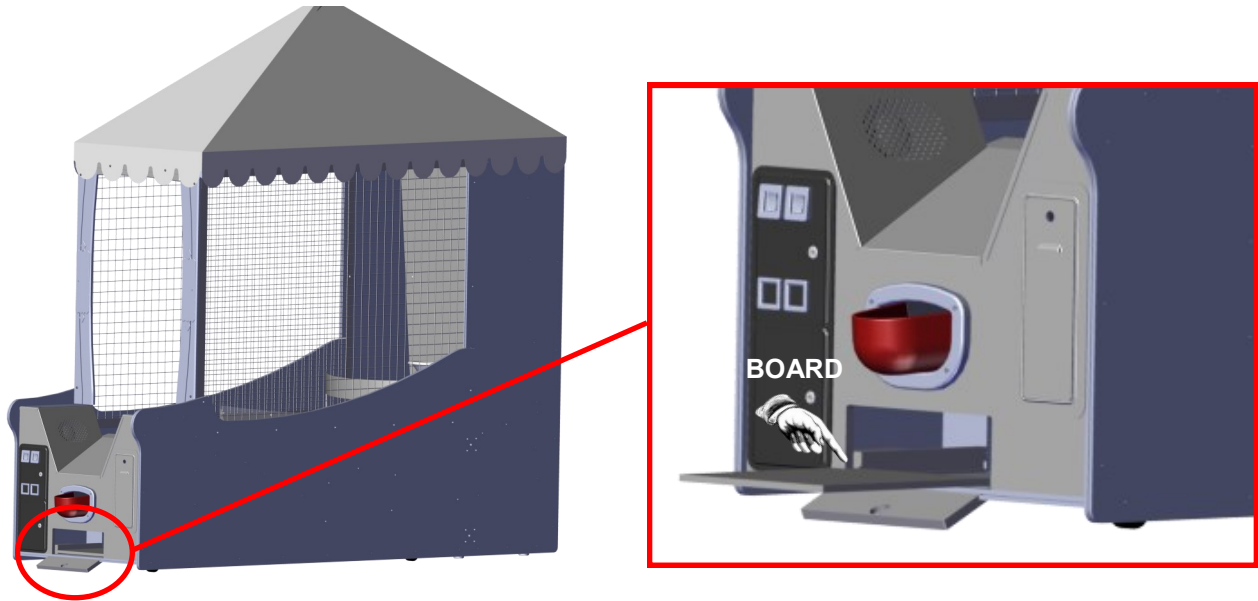

PLL Bulb Replacement

Attached to the back door are 3 PLL bulbs that provide back lighting to the cabinet. To replace a defective bulb, open the back door, remove the bulb clip, and press the red button to release the bulb from the socket. To install a PLL bulb, push the bulb down onto the socket, **DO NOT SLIDE THE BULB INTO THE SOCKET**, until you hear a “CLICK” noise from the socket. Now re-attach the bulb clip to complete the bulb replacement.

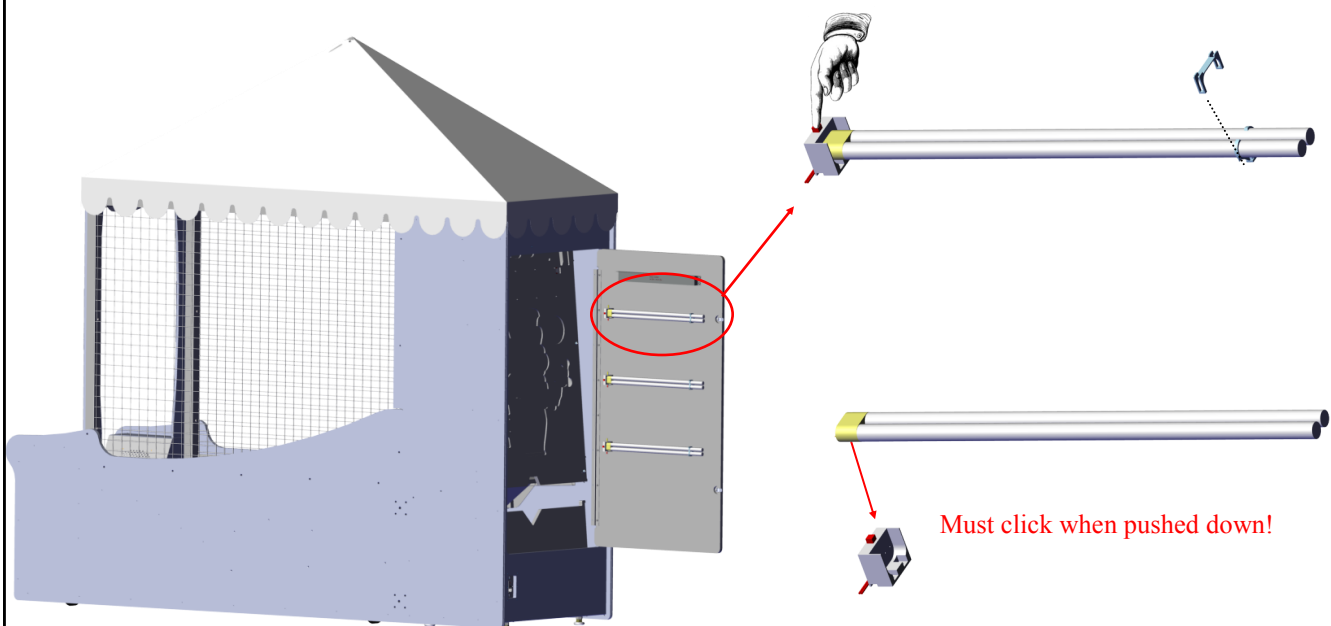

Ball Count Sensor Replacement

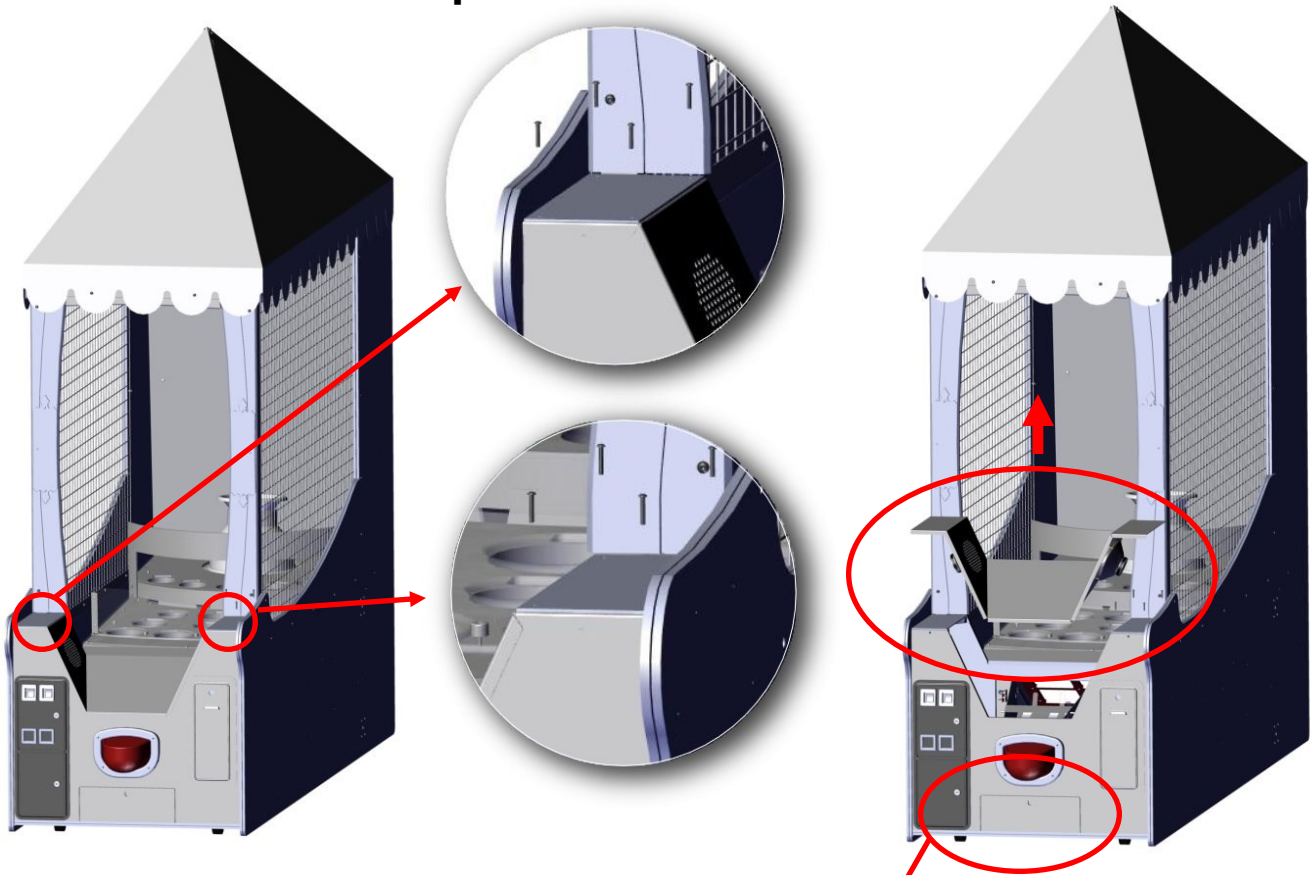

The game will not dispense balls if this sensor is not working. .

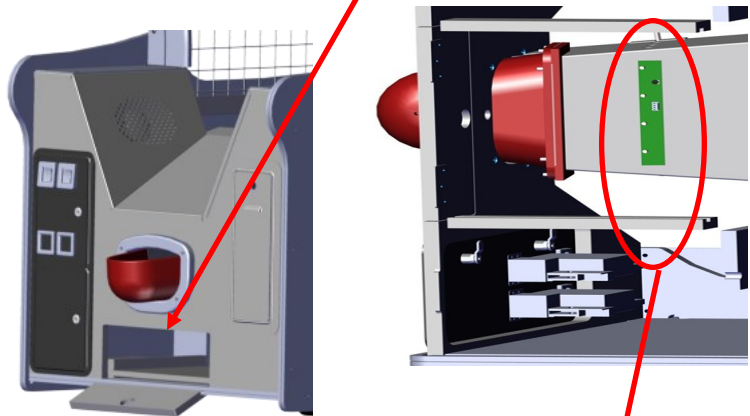

Score Sensor Replacement

There are three types of score sensors used in Milk Jug. MJ2037X, MJ2038X, and MJ2038SX. Following the instructions in section "Play Field Service" to gain access to these sensors. Both sensors mount the same way as shown. See Wiring insert for location of sensors or look below. Last number of part shown.

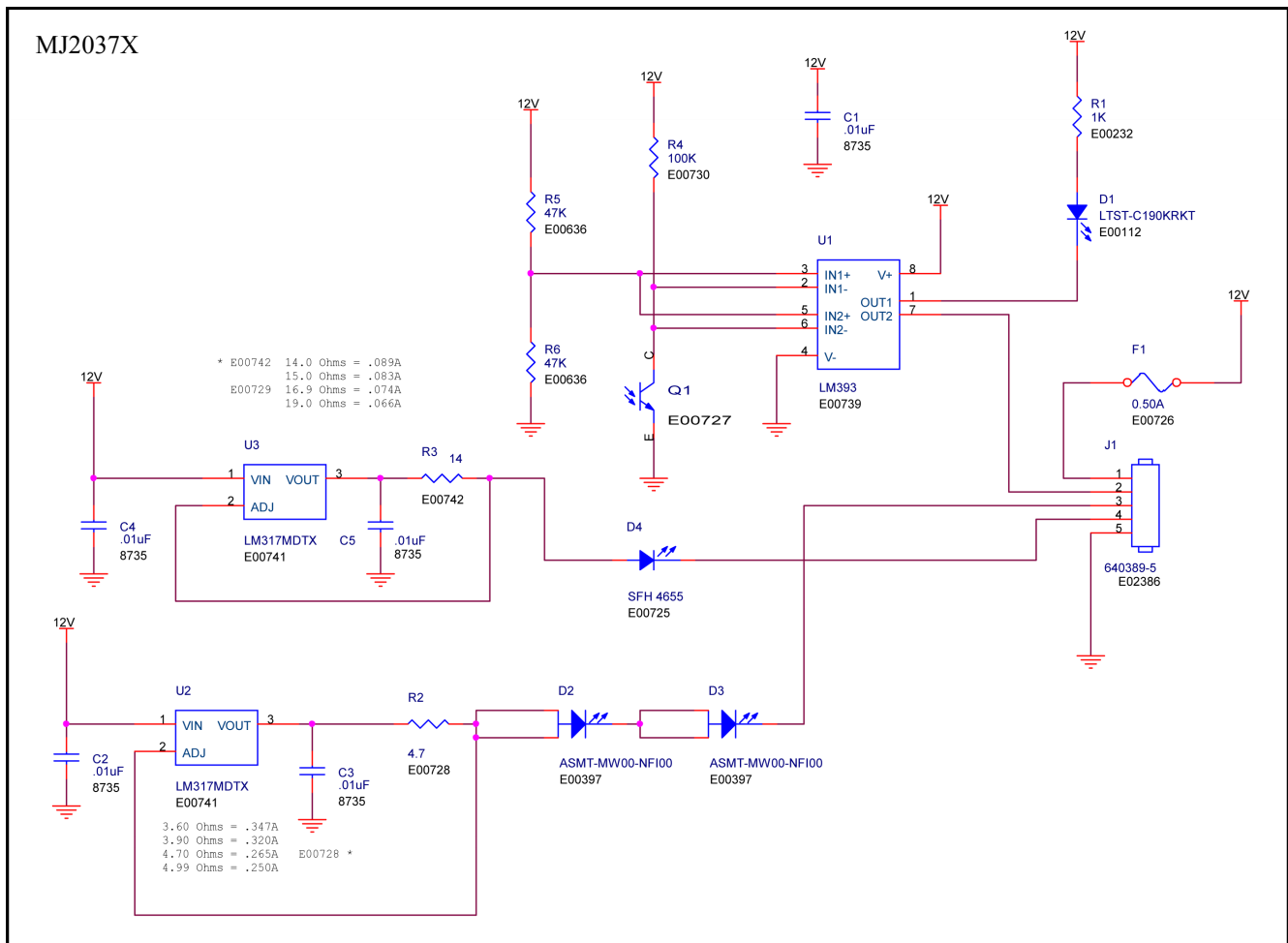
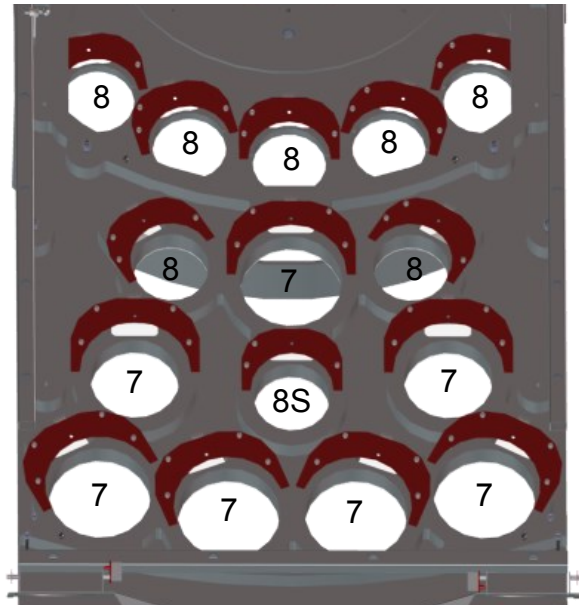
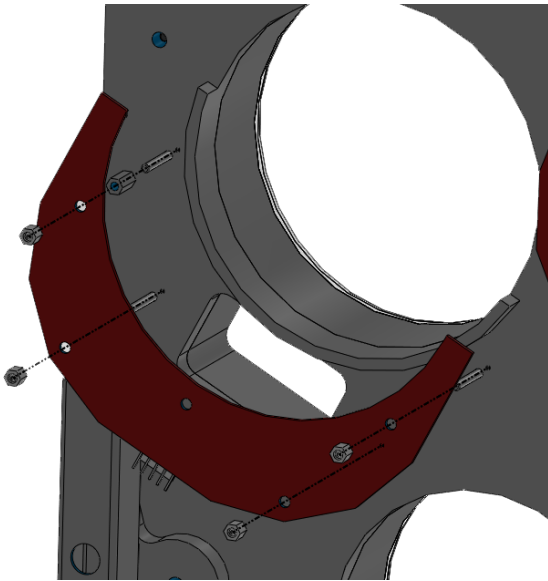

Score Sensor Replacement

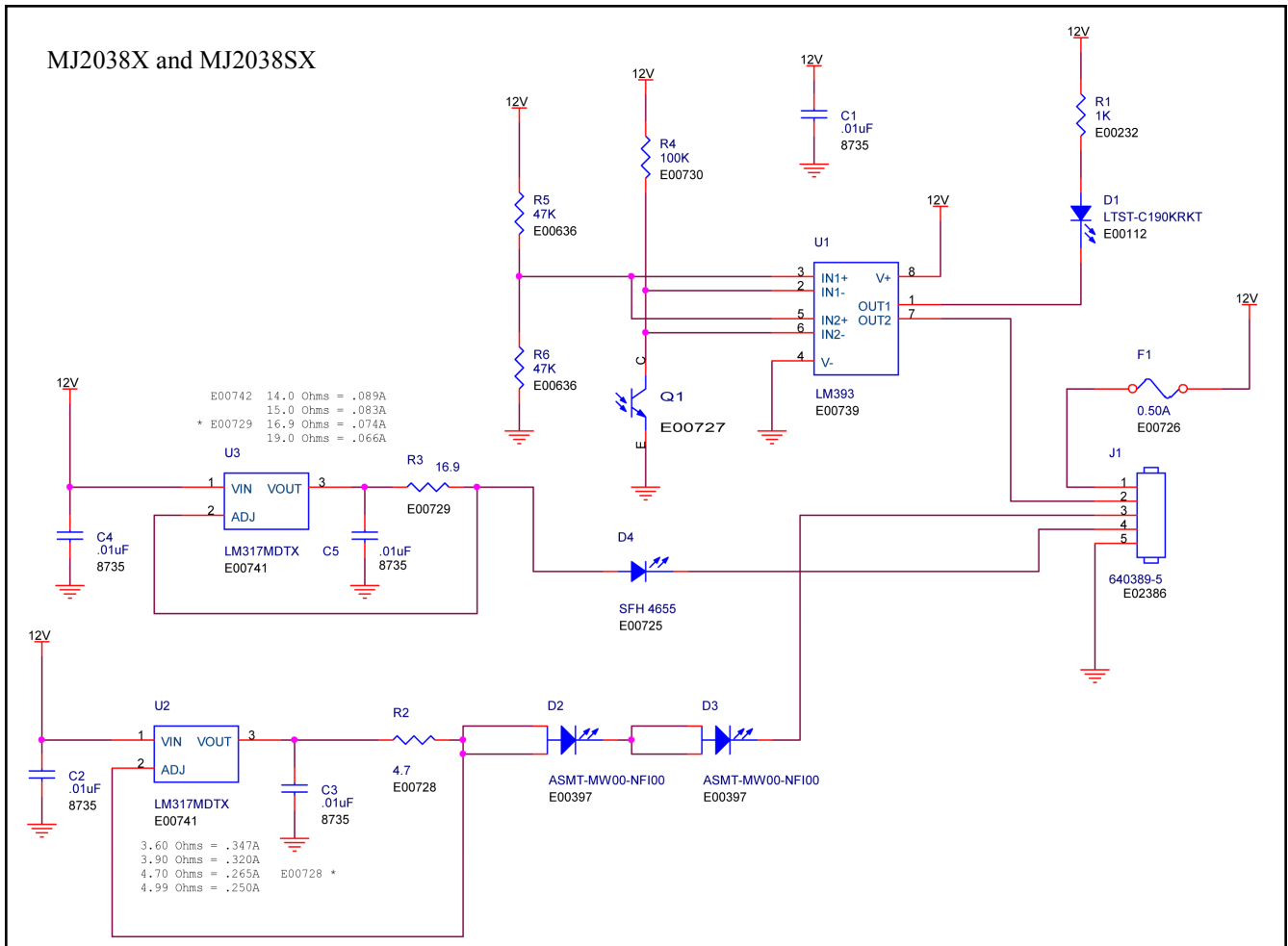

PR2039AX REV 2

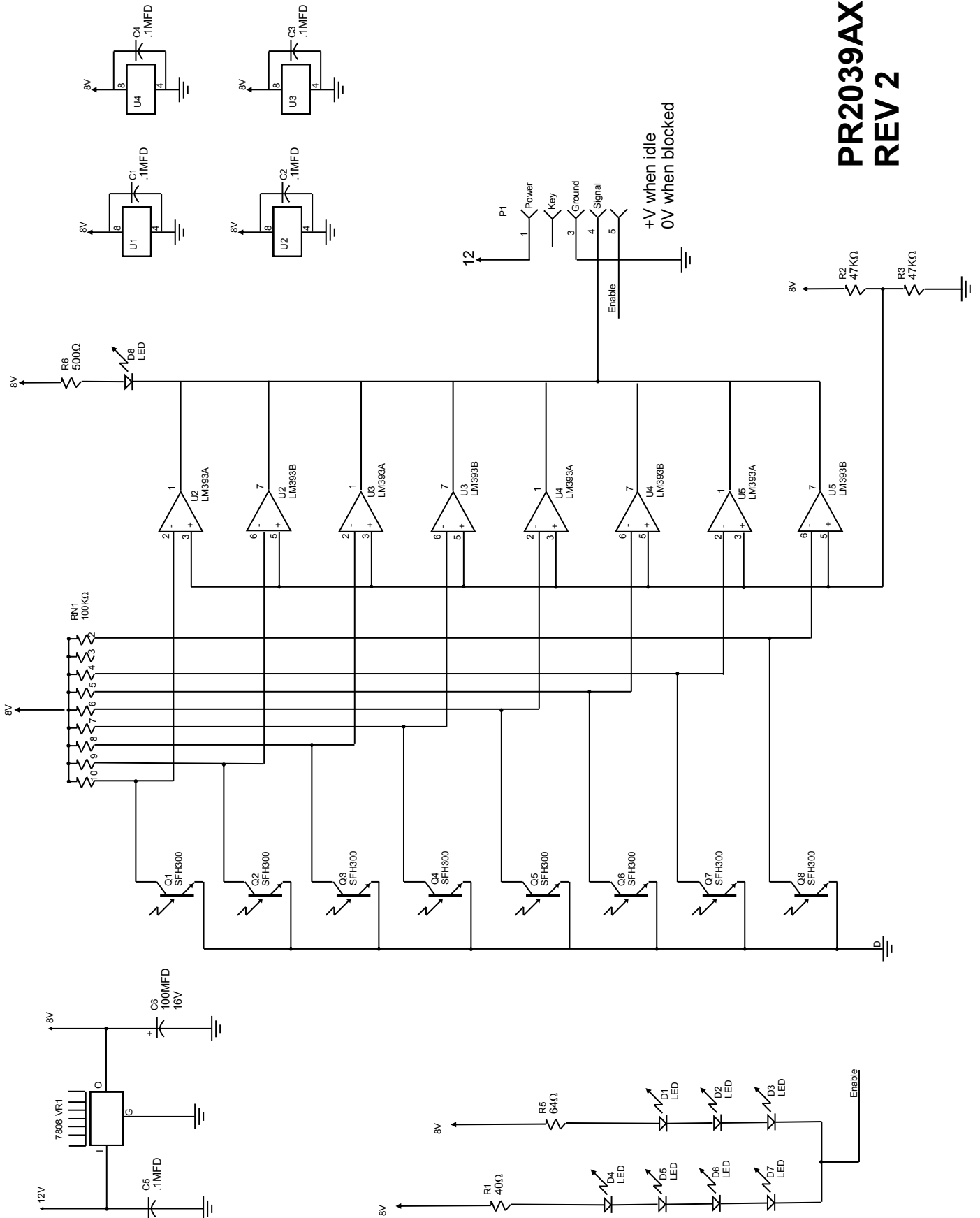

Power Supply Access

The power supply is a IA2010 and is accessed from the front of the game through the bottom drawer. See the section “Accessing the main board and power supply”.

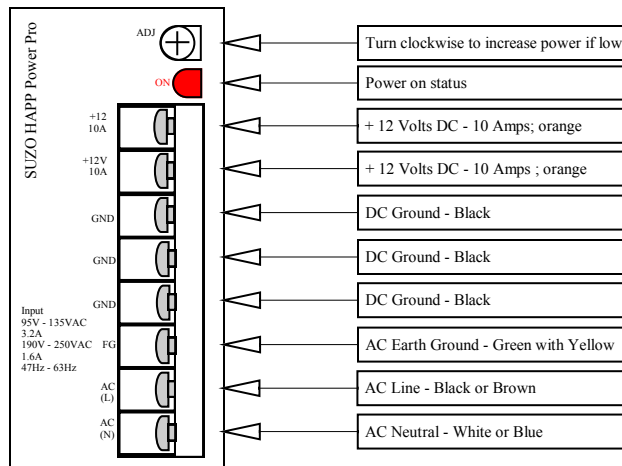

Checking DC Voltages

Volt test with the volt meter set to DC voltage. The +12 output can be adjusted by turning the adjustment screw of the power supply. Adjust to as close to +12 as possible. Increasing the +12. The voltage range can be plus or minus 5%.

Positive Probe:
Connect to +12V on power supply
(orange wire to power supply)

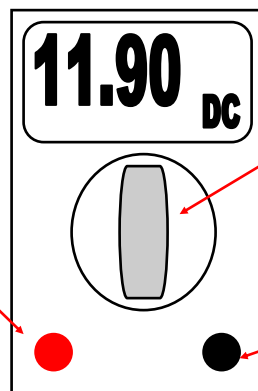

Turn to DC voltage check

Ground Probe:
Connect to GND on power supply
(Black wire to power supply)

Replacing Playfield Displays

Open the back door and remove the seven nuts that hold the display panel to the cabinet. Disconnect the display harnesses and remove the entire assembly.

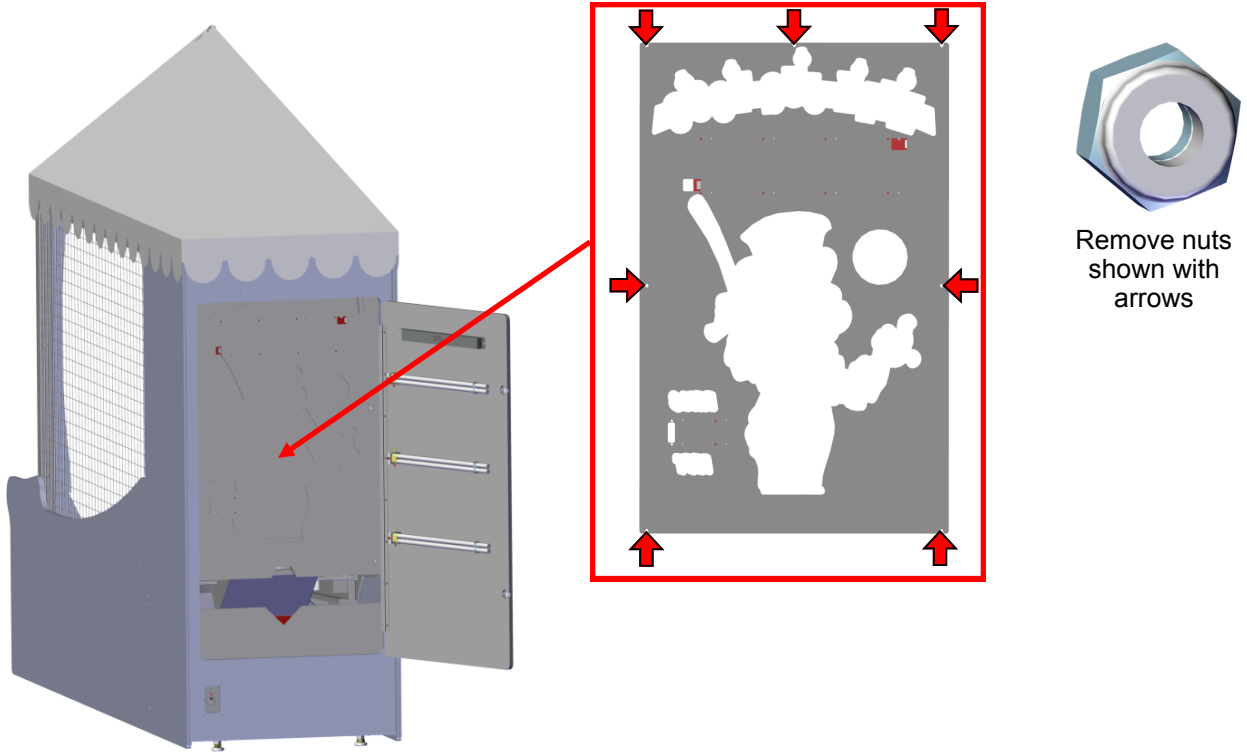

Lay the assembly on its back and remove the plastic standoffs to remove the display. Assembly in reverse order.

Small display is a DA2133X.
Large display is a RB2032X

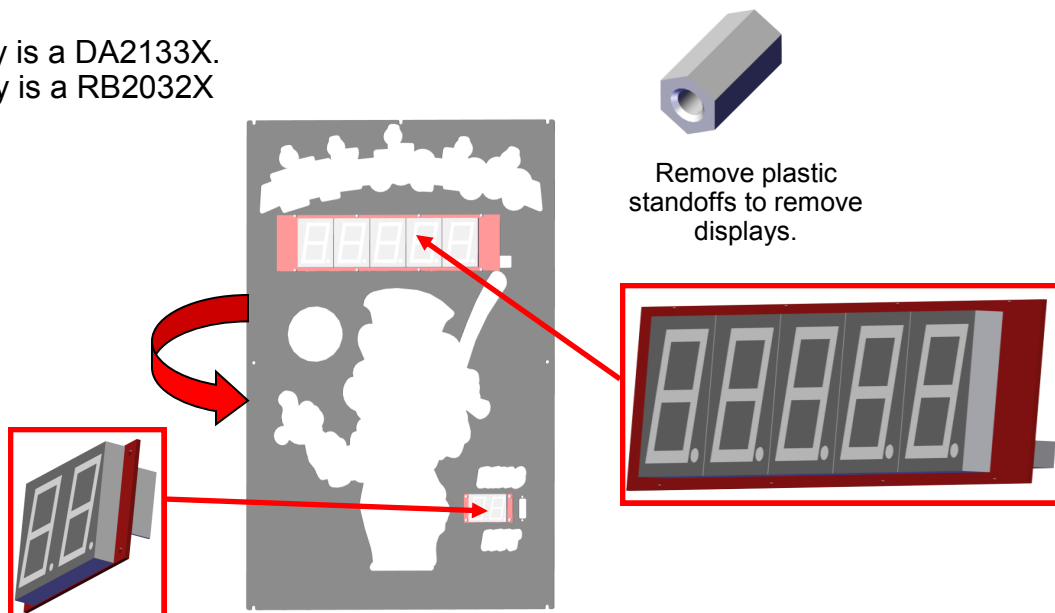

Safety Conveyor Sensor - RB2009BX

To access the safety conveyor sensors you only need to remove the front panel.

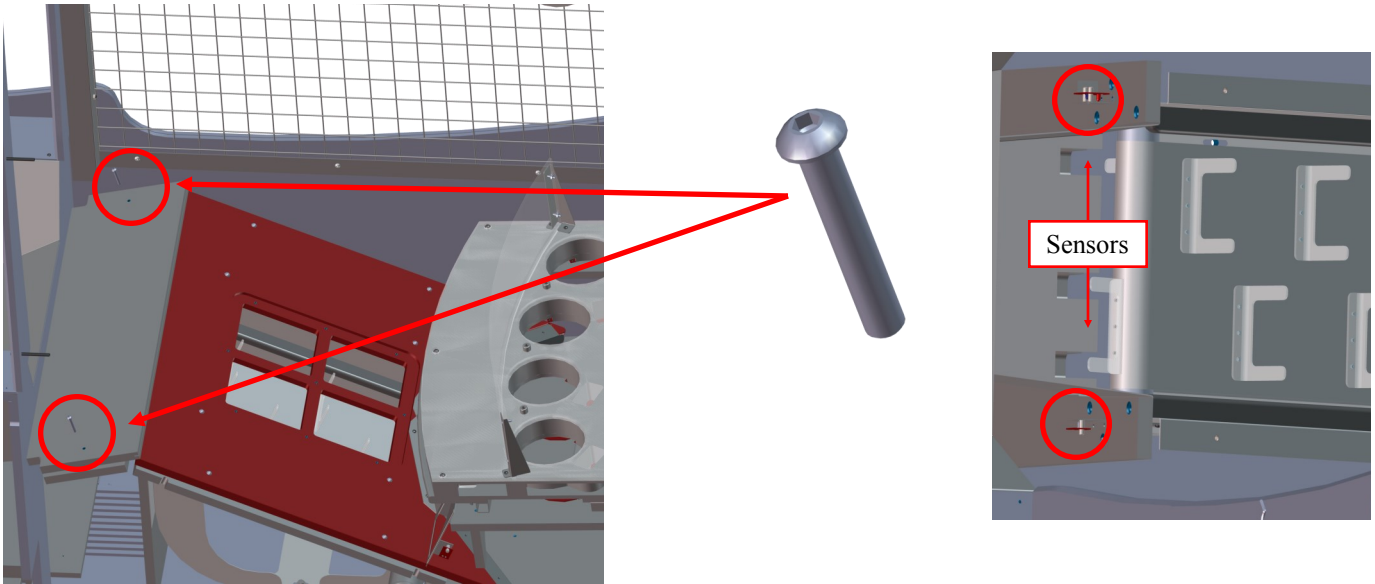

Conveyor Access

Remove the bolts shown with the arrows. Now remove the cover. The motor assembly is ICE part MJ2009X. The gearbox head is ICE part MJ2009A.

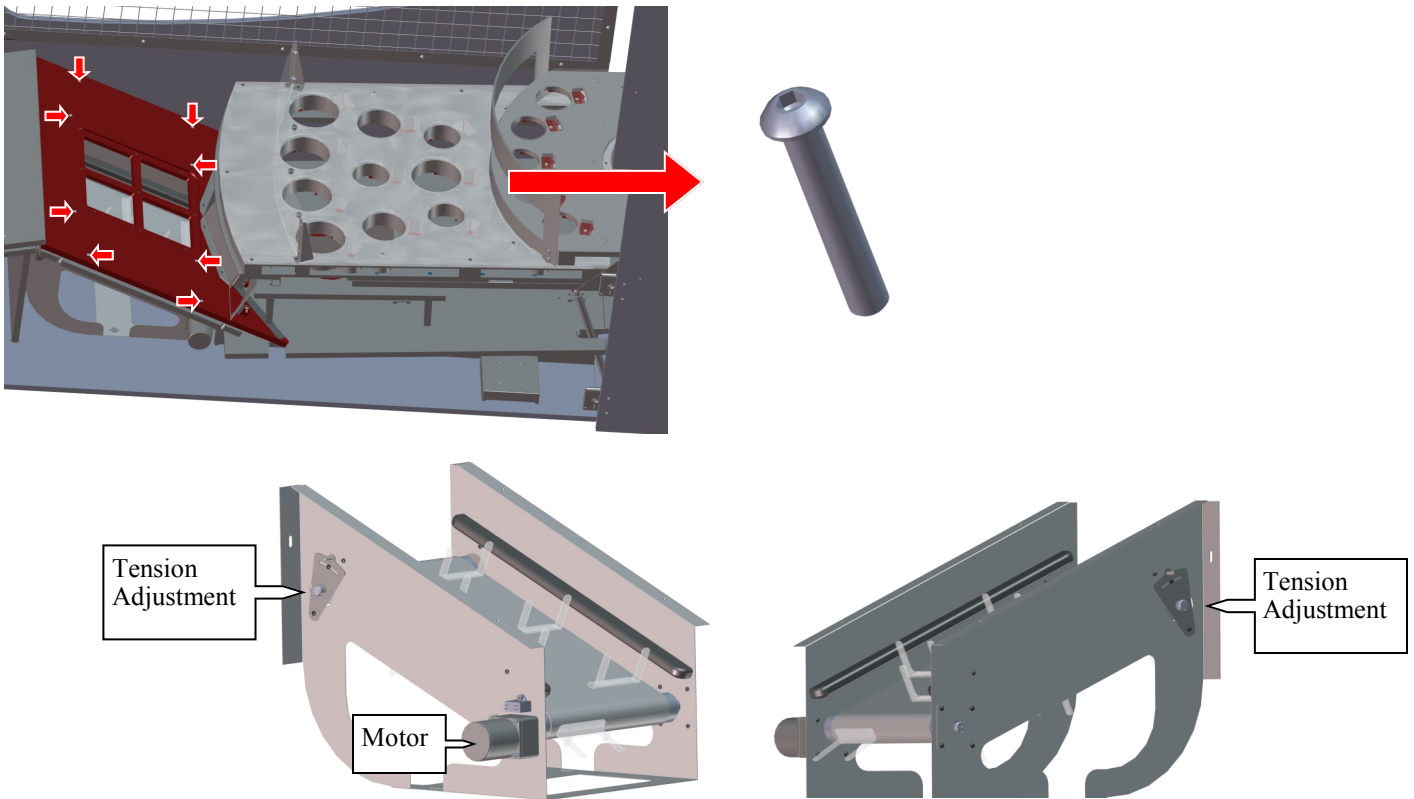

Optional Marquee - Bulb and Bonus display replacement

Remove the front panel of the marquee by unscrewing the screws at the locations shown with the circles below.

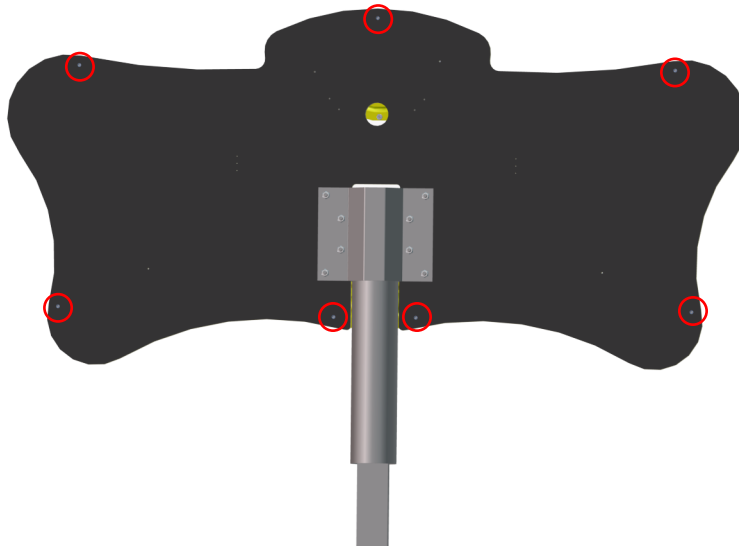

To replace the display, remove the four plastic stand off nuts that hold the display to the marquee.

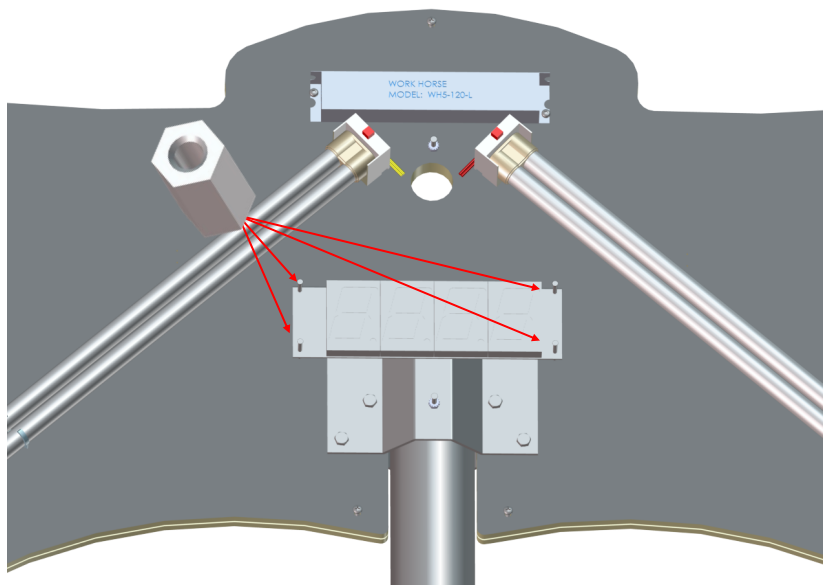

To replace a bulb, remove the plastic clip and press the red button to release the bulb. Be sure to push down on the bulb until it clicks when inserting a new bulb into the PLL socket.

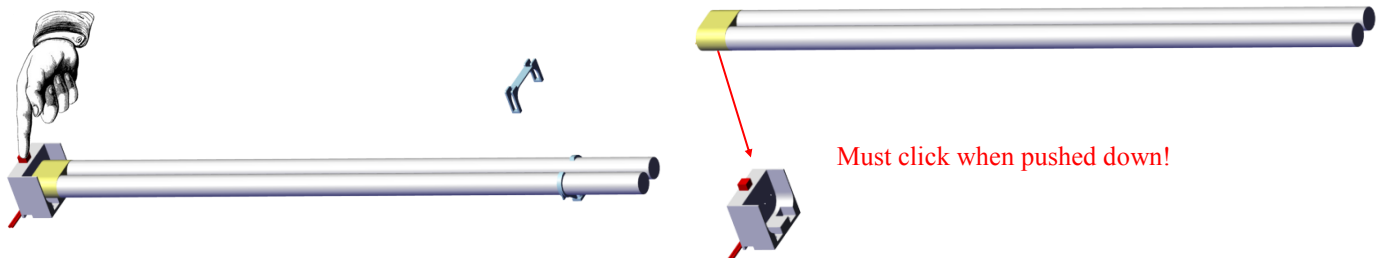

Main Schematics

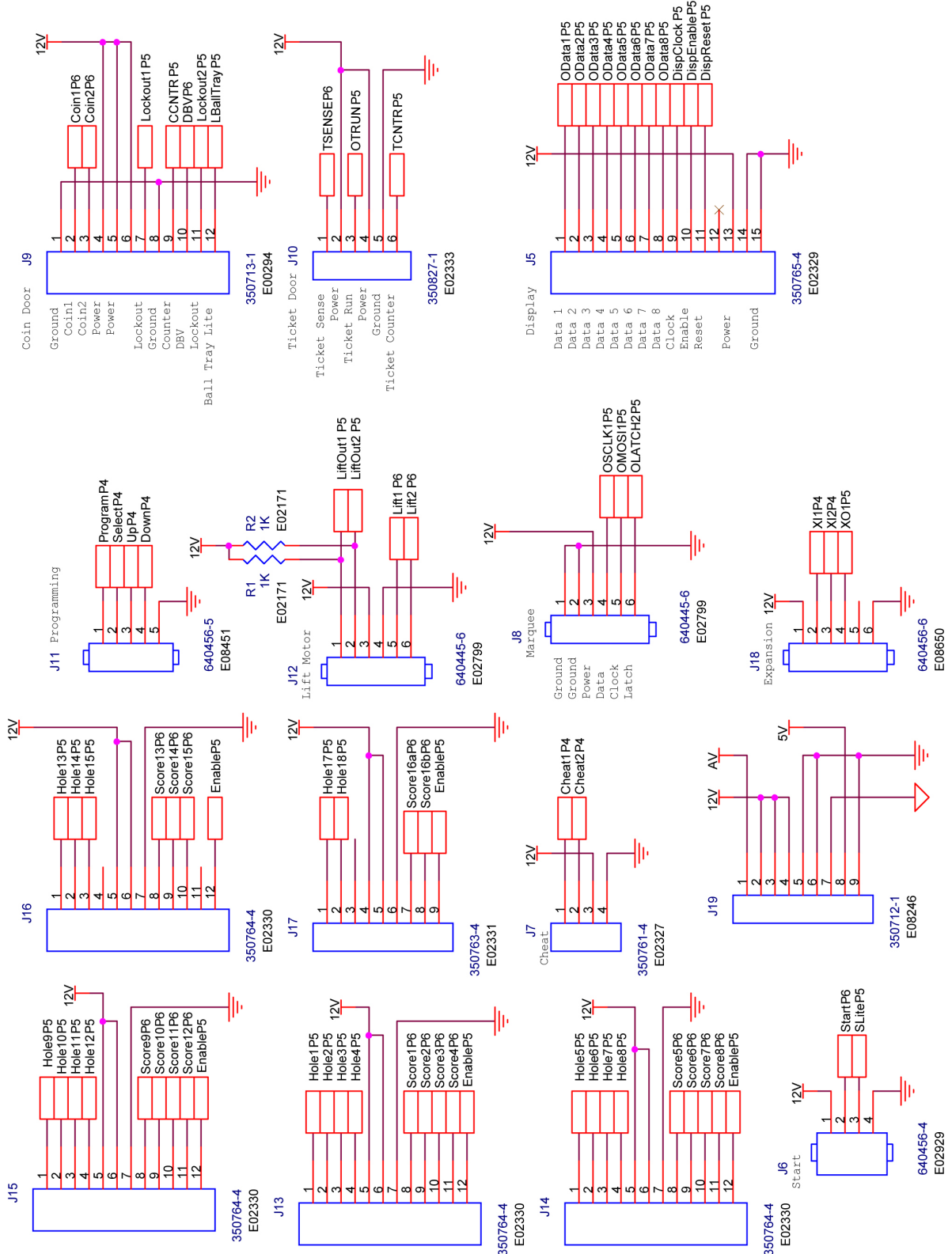

Main Schematics

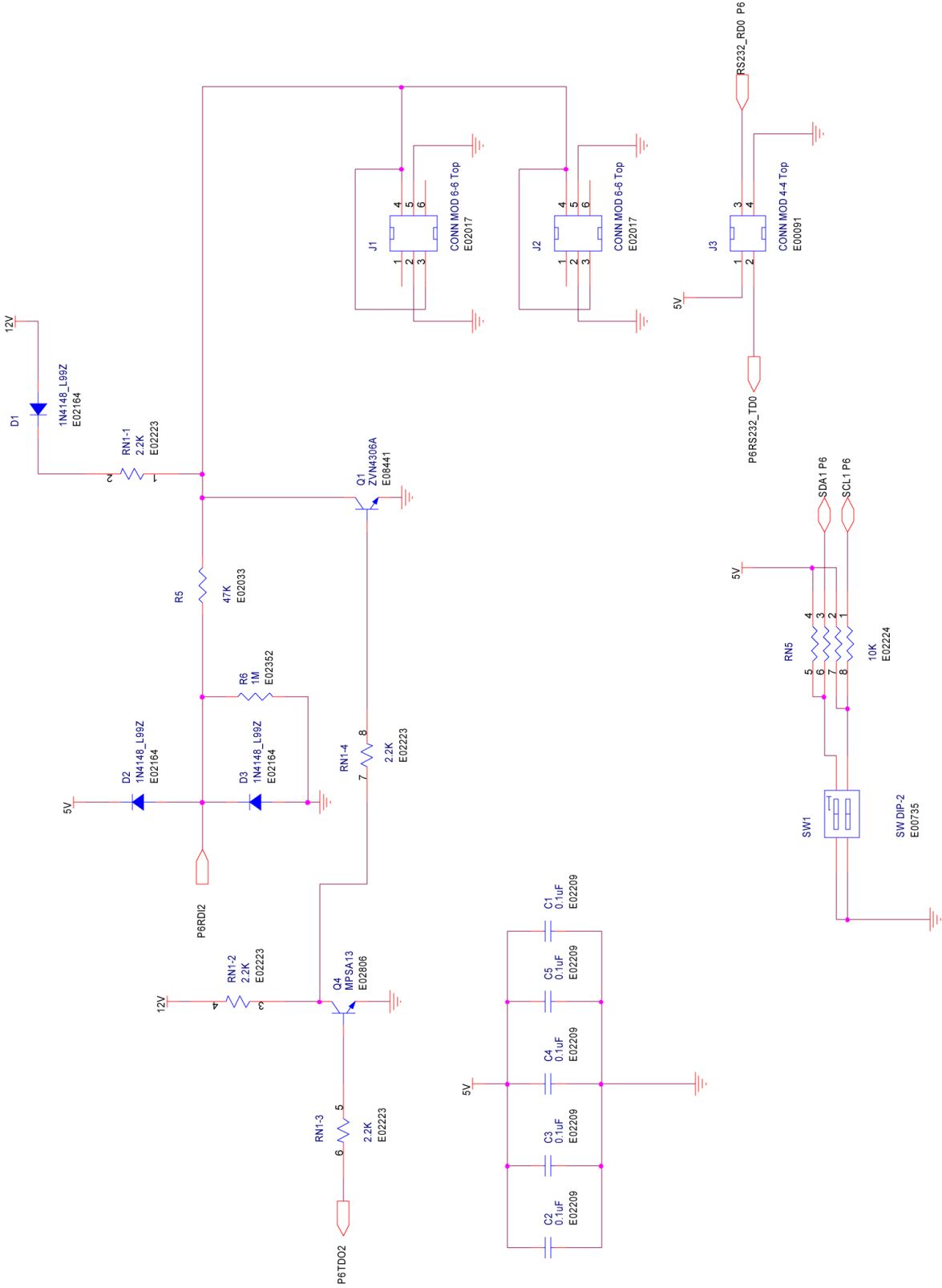

Main Schematics

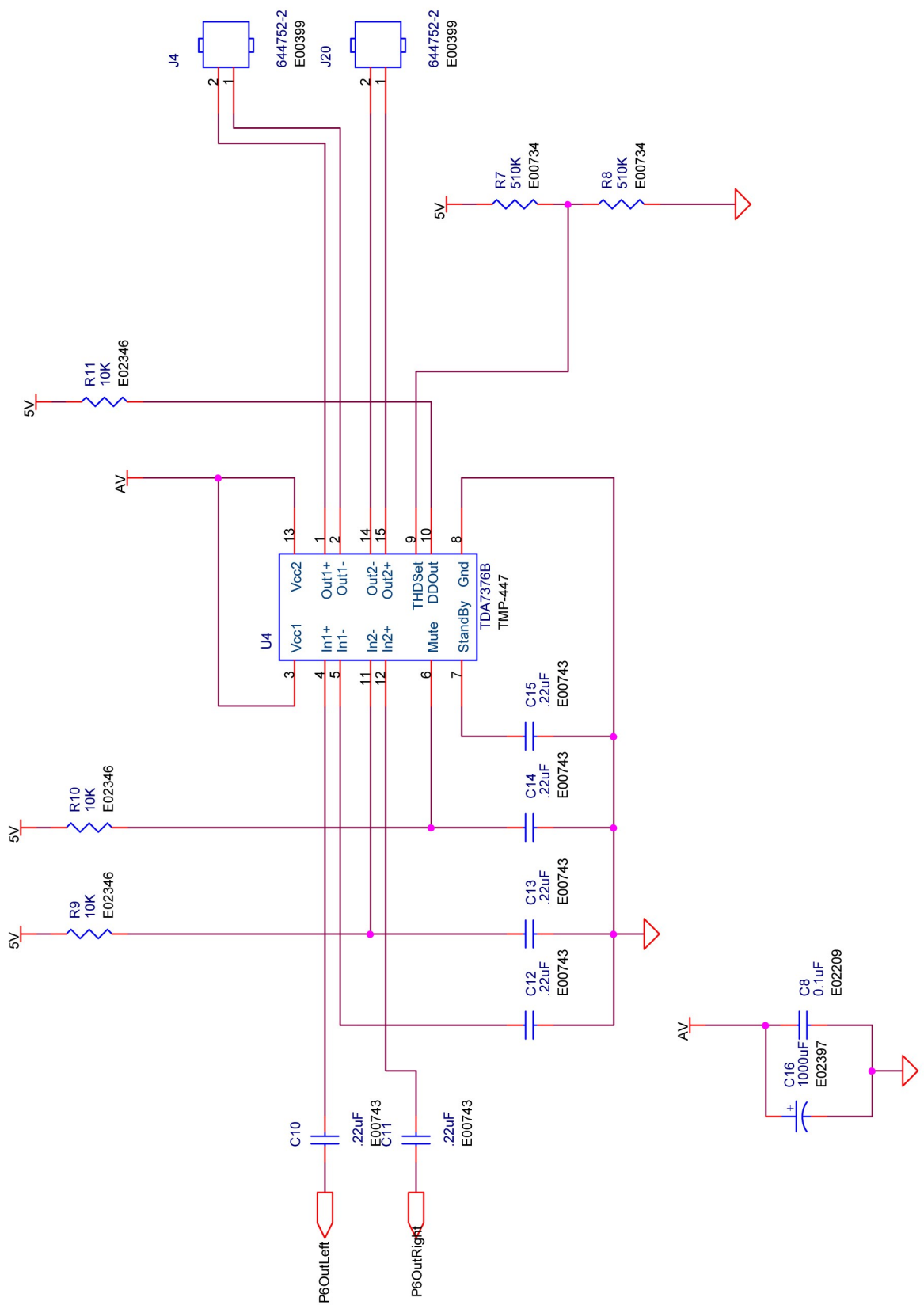

Main Schematics

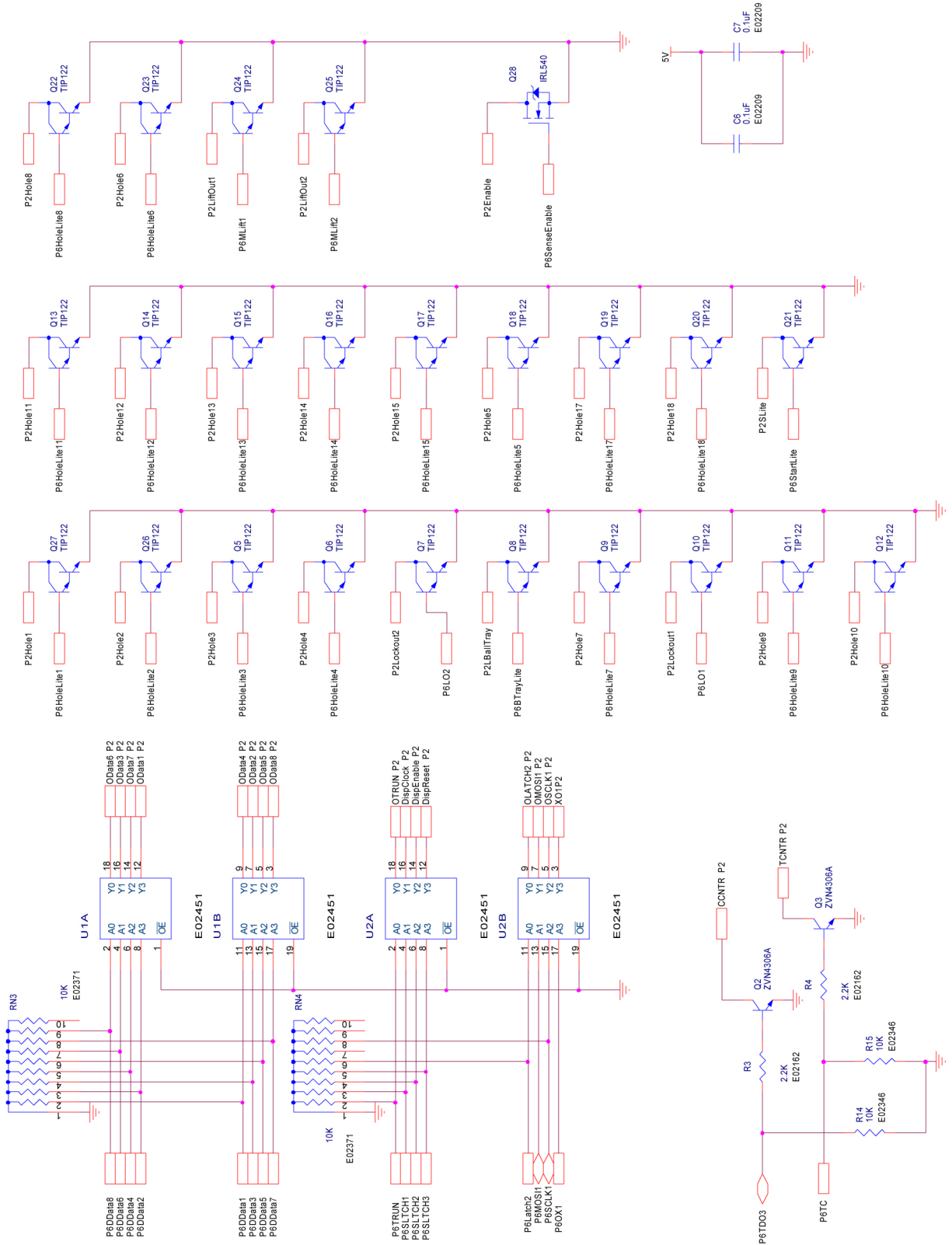

Main Schematics

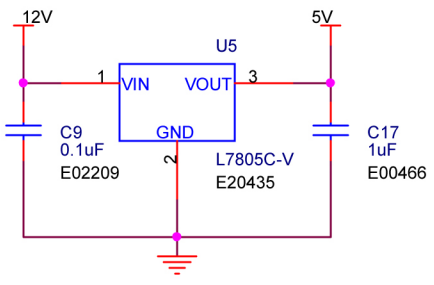
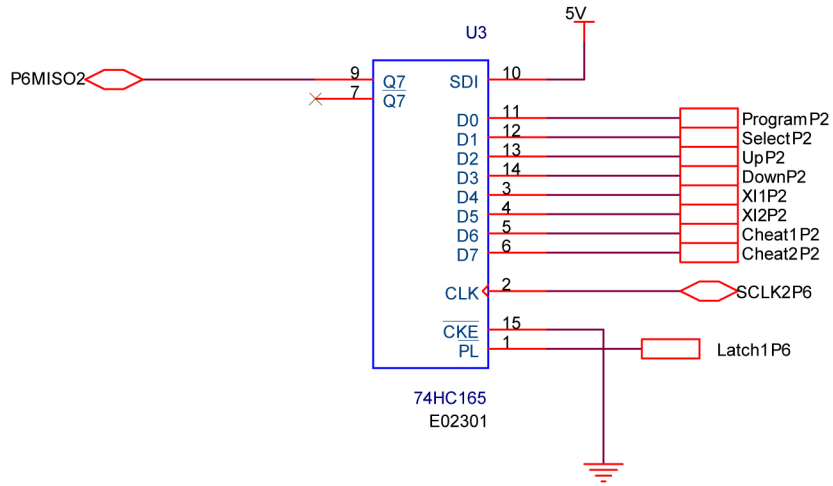

Spares List

Electronics:

| | Where used? |
|-----------|---|
| RB2032X | Big display board located behind playfield. |
| DA2133X | Small display board located behind the playfield. |
| PP250X | PLL bulbs located in the marquee and behind the playfield. |
| E00377 | Spot light used at top of game canopy. |
| E00670MJX | Workhorse 8 ballast used behind the playfield. |
| MJ2007X | Power module (6amps) used in back of game, incoming AC. |
| MJ2009A | Gearbox head for motor used in the conveyor. |
| MJ2009X | Motor assembly used in the conveyor. |
| MJ2037X | Score sensor (see playfield score layout). |
| MJ2038X | Score sensor (see playfield score layout). |
| MJ2038SX | Score sensor (same as MJ2038X but with a straight connector) |
| RB2009BX | Optical sensor, used in ball return and 50 point score sensors. |
| AR2007 | Speakers |
| IA2010 | 12 volt power supply used to power game. |
| 2111 | Ball conveyor relay. |
| MJ2034X | Main board with CPU board. |
| E00156 | Rocker switch |
| HH5005 | Ticket dispenser, used in front door assembly. |
| CX8384X | Marquee ballast, workhorse 5, used in marquee. |
| E00414MJX | Blue LED strip. |
| NA2032X | Marquee display |
| PR2039AX | Reflective sensor board used in ball conveyor. |
| 8982RBX | Pir sensor located in the top, left front of cabinet. |
| E00418MJX | White LED strip. |
| E02295 | 6 amp 250V slo blo mdl fuse |

Mechanical:

| | |
|--------|----------------------------|
| 211 | T-molding blue |
| BW2017 | Plastic clip for PLL bulbs |
| BW2018 | Plastic Bulb support |
| CG1052 | 3" swivel caster |
| CG3019 | Cage retainer cap |

Graphic Locations and Part Numbers





WARRANTY POLICY

I.C.E. Inc warrants all components in new machines to be free of defects in materials and workmanship for the period listed below:

- 180 days on Main PCB's, Computers & Motors
- 1 year on all LCD monitor panels
- 90 days on all other electronic and mechanical components
- 30 days on all I.C.E. repairs and parts purchases

I.C.E. Inc shall not be obligated to furnish a warranty request under the following conditions:

- Equipment or parts have failed through normal wear and tear
- Equipment has been subjected to unwarranted stress, abuse or neglect
- Equipment has been damaged as a result of arbitrary repair/modification

Products will only be covered under warranty by obtaining an I.C.E. authorized RMA #. To obtain an RMA # please provide I.C.E. tech support with the game serial # or original I.C.E. invoice # and a detailed description of the failure or fault symptoms.

I.C.E. Inc will assume no liability whatsoever for costs associated with labor or travel time to replace defective parts. All defective warranty covered components will be replaced with new or factory refurbished components equal to OEM specifications.

I.C.E. Inc will cover domestic UPS ground, or comparable shipping costs during the warranty period. International or expedited shipments are available for an additional charge. To obtain credit defective parts must be returned to I.C.E. Inc, at the customer's expense, within 30 days. After 30 days a 15% re-stocking fee will apply to all returns.

ICE distributors are independent, privately owned and operated. In their judgment, they may sell parts and/or accessories other than those manufactured by I.C.E. Inc. We cannot be responsible for the quality, suitability or safety of any non-I.C.E. part or modification (including labor) that is performed by such a distributor.

Innovative Concepts in Entertainment
10123 Main St.
Clarence, NY 14031
Phone #: (716) - 759 - 0360
Fax #: (716) - 759 - 0884
www.icegame.com